

JICA ASSISTED GUWAHATI WATER SUPPLY PROJECT

Loan Agreement No. ID P-201

IFB No.: GWSP/LB/C#12A/2018-19 Date: 31.01.2019

Contract Package No. C#12A:

Rate contract for providing Drinking Water House Service Connections in lots of 1,000 each, for total of approximately 5,000 households in South-west & south-central Guwahati area, providing all the required goods & materials, install the Employer supplied Water meters, install the pipes & accessories, excavation and road restoration works all complete

Bid Document For Contract Package No. C#12A

Limited Bidding

Bid Document For Contract Package No. C#12A

Rate contract for providing Drinking Water House Service Connections in lots of 1,000 each, for total of approximately 5,000 households in South-west & south-central Guwahati area, providing all the required goods & materials, install the Employer supplied Water meters, install the pipes & accessories, excavation and road restoration works all complete

CONTENTS

Sl. No.	Description	Page No.	
		From	To
1	Invitation for Bids under Limited Bidding (IFB)	IFB – 1	IFB – 2
2	Section I: Instructions to Bidders (ITB): Qualification of the Bidder, Bid Prices, Preparation of Bid, Bid Submission, Evaluation of Bids, Award of Contract, Performance Security	ITB – 1	ITB – 5
3	Section II: Bidding Forms – Technical (BFT): Letter of Technical Bid; Qualification Information	BFT – 1	BFT – 4
4	Section III: Bidding Forms – Financial (BFF): Letter of Financial Bid; Preamble to Price Schedule	BFF – 1	BFF – 3
	Bill of Quantities	BOQ - 1	BOQ - 7
5	Section IV: Scope of Works (ER)	ER - 1	ER-4
6	Section V: Technical Specifications (TS)	TS -1	TS -12
7	Section VI: Drawings (DRG)	DRG - 1	DRG - 8
8	Section VII: Contract Forms: (CF)		
	Draft Letter of Acceptance	CF - 1	CF - 1
	Articles of Contract Agreement with Conditions of Contract	CF - 2	CF - 7
	Performance Bank Guarantee	CF - 8	CF - 8
	Bank Guarantee for Advance Payment	CF - 9	CF – 9
	Contract data	1	4
9	Trained Plumber Details		

Office of the Project Director
Project Implementation Unit
JICA Assisted Guwahati Water Supply Project
2nd Floor, Saikia Commercial Complex, Christian Basti, GS Road,
Guwahati - 781 005, Assam, India.
 Tele-Fax - +91-361-2340132; Email: md.gjb@nic.in
www.gmdwsb.assam.gov.in

Invitation for Bids under Limited Bidding for fixing rate contract for providing Drinking Water House Service Connections

IFB No.: GWSP/LB/C#12A/2018-19

Date: 31.01.2019

JICA Loan No. and Title: ID P-201 Guwahati Water Supply Project.

Government of India has received loan from the Japan International Cooperation Agency (JICA) towards the cost of Guwahati Water Supply Project and it intends to apply part of the proceeds of this loan to payments under the contract for Procurement of works [Rate Contract] for providing drinking water House Service Connections under Contract Package No. C#12A.

Project Director, JICA Assisted Guwahati Water Supply Project, Guwahati invites sealed Bids for the works as detailed below:

Sl. No.	Item	IFB No.: GWSP/LB/C#12A/2018-19 Date: 31.01.2019
1	Work Description	Rate contract for providing Drinking Water House Service Connections in lots of 1,000 each, for total of approximately 5,000 households in South-west & south-central Guwahati area, providing all the required goods & materials, install the Employer supplied Water meters, install the pipes & accessories, excavation and road restoration works all complete.
2	Time for Completion	3 Months.
3	Duration for obtaining the Bid documents directly from the Employer or by downloading from the designated Website.	01.02.2019 to 14.02.2019 Office of the Project Director, PIU, JICA Assisted Guwahati Water Supply Project, 2 nd Floor, Saikia Commercial Complex, Christian Basti, Guwahati – 781 005, Assam. www.gmdwsb.assam.gov.in . Amendments if any will be informed in the above website only.
4	Bid document fee	Rs. 2,000 for purchase from the Employer and if required through post additional cost of INR 250.
5	Bid Security	Rs. 1.90 Lakhs per lot of 1,000 connections.
6	Pre Bid Meeting	06.02.2019 at 10.00 Hours. Place: Office of the Project Director, JICA Assisted Guwahati Water Supply Project, 2 nd Floor, Saikia Commercial Complex, Christian Basti, Guwahati -781 005.
7	Last Date & Time for Physical Submission of Bids	14.02.2019; Time:15.00 Hours
8	Date & Time for Opening Bids	14.02.2019; Time:15.30 Hours

Bidding will be conducted through the Limited Bidding & Rate Contract procedures specified in the Section 30 and 36 of Assam Public Procurement Act 2017, are open to eligible bidders. Single-Stage-Two-Envelope Bidding will be adopted.

Interested eligible Bidders may obtain further information from the Project Director, JICA assisted Guwahati Water Supply Project, Guwahati and inspect the Bidding documents on the working days during 10 AM to 5 PM or seen on the website: www.gmdwsb.assam.gov.in.

Any Bidder may submit their Bids for maximum of 2 lots. In such case, it will be evaluated whether the Bidder demonstrates that it has twice the Physical & Financial criteria, prescribed for one lot.

The payment towards the Bid document will be through demand draft in favour of “The Project Director, JICA Assisted Guwahati Water Supply Project” payable at Guwahati, Assam.

Bids received without Bid Security shall be rejected out rightly. Bids delivered after the time and date noted above will be rejected.

The Employer will not be responsible for any costs or expenses incurred by Bidders relating to the preparation or delivery of Bids.

The Employer reserves the right to accept any bid, or reject any or all bids, without assigning any reason thereof and without thereby incurring any liability to the Bidder or Bidders.

(Dr. Siddharth Singh)
Project Director,
JICA Assisted Guwahati Water Supply Project
Guwahati- 781 005.

Section. I: Instructions to Bidders

1. Scope of Works

The Project Director, JICA Assisted Guwahati Water Supply Project, Guwahati (Employer) invites quotations for the works as detailed below:

Brief Description of the Works	Period of Completion
Package C#12: Rate contract for providing Drinking Water House Service Connections in lots of 1,000 each for total of approximately 5,000 households in South-west & south-central Guwahati area, providing all the required goods & materials, install the Employer supplied Water meters, install the pipes & accessories, excavation and road restoration works all complete.	3 Months

The successful Bidder will be expected to complete the works by the intended completion date specified above.

2. Qualification of the Bidder:

A Bidder may be a single entity, be a manufacturer **or** Civil Main contractor **or** Sub-contractor **or** any combination of such entities in the form of a joint venture (JV) comprising maximum of two partners, under an existing agreement or with the intent to enter into such an agreement supported by a letter of intent.

If it is a JV, each partner shall have the work share. The Letter of Intent or the JV Agreement shall spell out their specific role, i.e., civil works, supply of pipes & specials, etc., of each partner.

2.1. Qualification Information to be provided by the Bidder: the Bidder shall provide information on his qualification which shall include:-

- a) Total monetary value of works executed by the Main contractor **or** Sub-contractor / production & sales made by the manufacturer, for each year of the last 3 years;
- b) List of works completed satisfactorily as a prime contractor or sub-contractor during the last 3 years, enclosing evidences from the respective Employers in support of experience claimed or sufficient documentary proof;
In case of a manufacturer, he shall submit the credentials, such as BIS Certification and Proof of production & Sales during the last 3 years,
- c) Report on his financial standing, along with last 3 years' financial statements/Profit and Loss Statements; and
- d) Details of any litigation, during the last 3 years in which the bidder is involved, the parties concerned, and disputed amount or award in each case (Give details of both completed and pending cases).

2.2. Qualification Criteria: to qualify for award of the contract the bidder:-

- (a) Should be a manufacturer having ISI license for PE Pipes & specials **or** registered Civil Contractor/ Sub-contractor, registered with Assam PHED, Assam PWD, AUWSSB, GMC or GMDA.
- (b) Should have average Annual turnover of **INR 1.50 crore for the single Entity**, calculated as total certified payments received for contracts in progress or completed during the past 3 years, ie., starting from 1st April 2015;

In case of JV, the JV together must meet the above criteria of INR 1.50 crore.

- (c) The Bidder must demonstrate access to, or availability of, financial resources such as liquid assets, unencumbered real assets, lines of credit, and other financial means, other than any contractual advance payments to meet:

Minimum cash-flow requirement: **INR 30 lakhs** during the duration of Contract.

In case of JV, the JV together must meet the above criteria of INR 30 lakhs.

(d) Work Experience: The Bidder who can be

- (i) A manufacturer of PE Pipes, during the last 3 years as a minimum, who shall submit the credentials, such as BIS Certification and Proof of Sales **or**
- (ii) A Civil contractor working for a municipality / Government Departments/ Undertakings in India and having experience during the last 3 years, from 1st April 2015 and Bid submission deadline, in Laying & jointing of DI/ PE/PPR/MS pipelines of at least **2 km**, for which the Bidder shall submit the credentials from the Employer, **or**
- (iii) A Subcontractor, if he had worked under any Main Contractor for the ongoing JICA/JnNURM/ADB funded Water Supply Projects for Guwahati and having Experience during the last 3 years, from 1st April 2015 and Bid submission deadline, in Laying & jointing of DI/ PE/PPR/ MS pipelines of at least **2 km**, for which the Bidder shall submit the appropriate/required proof, such as the Work order, Contract and Proof of payment given by the main contractor.

3. Eligibility – Conflict of Interest: A Bidder (a) shall not have conflict of interest as defined in the JICA's Procurement Guidelines; and (b) should not have been (i) temporarily suspended or debarred by the World Bank Group in compliance with the Bank's Anti-Corruption Guidelines and its Sanctions Framework; or (ii) blacklisted or suspended by Central or any State Government Departments in India.

4. Clarifications & Amendments: If the Employer receives any request for clarification of this Bid document, it will upload its response together with any amendment to this document, on the www.gmdwsb.assam.gov.in for information of all Bidders.

5. Bid Prices:

- a) The Bid shall be for construction of the whole works as described in the Bill of quantities, drawings and technical specifications.
- b) All duties, taxes and other levies payable by the contractor under the contract shall be included in the total price.
- c) The rates quoted by the bidder shall be fixed for the duration of the contract and shall not be subject to adjustment on any account.
- d) The rates should be quoted in Indian Rupees only.

6. Preparation of Bid:

6.1 The Bidder is advised to visit the site of works at his own expense and obtain all information that may be necessary for preparing the Bid.

6.2 **Each Bidder shall submit only one Bid and maximum for 2 lots.** In such case, it will be evaluated whether the Bidder demonstrates that it has twice the Physical & Financial criteria, prescribed for one lot.

6.3. Bidders shall not contact other Bidders on matters relating to this Bid.

6.3 The Bid shall comprise two Parts, namely the Technical Bid and the Financial Bid. Both Parts shall be submitted simultaneously.

6.4 The Technical Bid shall comprise the following:

- (a) **Letter of Technical Bid** as per Format given;
- (b) **Authorization:** Power of Attorney of signatory of Bid;
- (c) Copy of registration as the Civil Contractor with Assam PHED, Assam PWD, AUWSSB, GMC or GMDA **or** in case of a manufacturer, BIS Certification and GST Registration. [ITB Clause 2.1 (a)];
- (d) **Annual Turnover:** Confirmation showing Annual Turnover in civil Engineering construction works of similar nature **or** in case of a manufacturer, manufacturing and sales, in the last three financial years. [ITB Clause 2.1 (c) and 2.2 (c)].
- (e) **Qualifications:**
 - (i) Qualification information and supporting documents relating to similar nature of works executed and payments received. In case of manufacturer, proof of production and sales and major supplies made to the Government Departments, projects, etc., [ITB Clause 2.1 (b) and 2.2 (b)];
 - (ii) Documents to support cash flow details [ITB Clause 2.2 (c)];
 - (iii) Documents to support the claim for Work Experience [ITB Clause 2.2 (d)];
- (f) Complete address and contact details of the Bidder having the following information:
 - Name of the Bidder
 - Address for communication
 - Telephone No(s): Office
 - Mobile No.
 - Facsimile (FAX) No.
 - Electronic Mail Identification (E-mail ID)
- (g) The Technical Bid shall not include any financial information related to the Bid price. Where material financial information related to the Bid price is contained in the Technical Bid, the Bid shall be declared non-responsive.

6.5 The Financial Bid shall comprise the following:

- (a) Letter of Financial Bid;
- (b) Priced Bill of Quantities.

6.6 Signing of Bid: The name and position held by the person signing the Bid and related documents must be typed or printed below the signature.

6.7 Deadline for Submission of Bid: Bids must be submitted no later than the deadline for submission of Bids viz. time **15.00 hours and date 14.02.2019**. A Bidder may modify its Bids any number of times, before the deadline for submission of Bids.

6.8 Validity of Bid: Bid shall remain valid for a period not less than **45 days** after the deadline date specified for submission.

7. Bid Submission:

The Technical Bid and Financial Bid shall be filled, signed and shall be placed in separate envelopes, which shall bear the Bid Invitation Number and specify whether, Technical Bid or Financial Bid.

Then, both the sealed envelopes shall be placed in a single bigger envelope, sealed and shall bear the Bid Invitation Number.

Both inner and outer envelopes shall bear the Bidder's name and address.

- 8. Opening and Evaluation of Technical Bids:** The ‘Technical Bids’ will be opened on the specified date and time, in presence of the Bidders’ representatives, who choose to be present.

The Financial Bids shall remain unopened, until the subsequent opening, following the evaluation of the Technical Bids.

- (a) The Employer shall examine the technical Bid to determine whether the Bid (a) has been properly signed; (b) meets the eligibility criteria; (c) is substantially responsive to the requirements of the Bid document; and (d) meets the qualification criteria specified in ITB Clause 2.
- (b) Only the Bids that are both substantially responsive to the Bid requirement and meet all Qualification Criteria shall qualify for opening of the Financial Bid.
- (c) Employer shall notify in writing those Bidders who have failed to meet the Qualification Criteria or whose Bids were considered non-responsive to the requirements in the Bid document, advising them that their Technical Bid failed to meet the requirements and that their Financial Bid shall not be opened and return their Bid Security.
- (d) Simultaneously Employer shall notify in writing those Bidders whose Technical Bids have been evaluated as substantially responsive and meeting the Qualification Criteria that their Bid has been evaluated as substantially responsive to the Bid document and that their Financial Bid will be opened on the date and time to be specified.

- 9. Opening and Evaluation of Financial Bids:** The ‘Financial Bid’ will be opened on the specified date and time, in presence of the Bidders’ representatives, who choose to be present.

- (a) The Employer shall examine and confirm that the Letter of Financial Bid and Priced Bill of Quantities are in accordance with the requirements specified in the Bid document. If any of these documents or information is missing, the offer shall be rejected.
- (b) During the evaluation of Financial Bid, the substantial responsiveness of the Bids will be further determined with respect to those Bid conditions that were not examined in evaluation of Technical Bids.
- (c) During the Evaluation of Price Bids, the Employer shall correct arithmetical errors on the following basis:
 - (i) where there are errors between the total of the amounts given under the column for the price breakdown and the amount given under the Total Price, the former shall prevail and the latter will be corrected accordingly;
 - (ii) if there is an error in a total corresponding to the addition or subtraction of subtotals, the subtotals shall prevail and the total shall be corrected; and
 - (iii) if there is a discrepancy between words and figures, the amount in words shall prevail, unless the amount expressed in words is related to an arithmetic error, in which case the amount in figures shall prevail subject to (i) and (ii) above.
- (d) Bidders shall be requested to accept correction of arithmetical errors. Failure to accept the correction, shall result in the rejection of the Bid.

10. Confidentiality:

Information relating to the evaluation of Bids and recommendation of Contract award, shall not be disclosed to Bidders or any other persons not officially concerned with such process until information on Contract award is communicated to all Bidders.

Any attempt by a Bidder to influence the Employer in the evaluation of the Bids or Contract award decisions may result in the rejection of its bid.

From the time of Bid opening to the time of Contract award, if any Bidder wishes to contact the Employer on any matter related to the bidding process, it shall do so in writing.

11. Award of contract

The Employer will award the contract to the Bidder, whose Bid has been determined to be substantially responsive and who has offered the lowest evaluated Bid price and who meets the specified qualification criteria.

11.1 Notwithstanding the above, the Employer reserves the right to accept or reject any Bids and to cancel the bidding process and reject all Bids at any time prior to the award of contract.

11.2 The Bidder whose Bid is accepted will be notified of the award of contract by the Employer prior to expiration of the Bid validity period.

12. Performance Security:

Within 7 days of receiving letter of acceptance, the successful Bidder shall deliver to the Project Director, JICA Assisted Guwahati Water Supply Project, Guwahati (Employer), the performance security (either a Bank guarantee or a Bank draft in favour of the Employer) for an amount equivalent of 10 % of the contract price.

The Performance Security shall be valid till the expiry of the period of the Contract, specified in Clause 12. Failure of the successful Bidder to furnish performance security and to sign the agreement within the period stipulated shall constitute sufficient grounds for annulment of award and debarring the Bidder from participation in bidding for works by the Employer for a period of one year, in which case the Employer may make the award to the next lowest evaluated bidder or seek Bids afresh.

13. Defect liability period:

The defects or other faults which may appear during the defect liability period of 12 months after the virtual completion of the work [lot], arising in the opinion of the Employer due to bad workmanship not in accordance with the contract, contractor shall make good the works at his own cost within a reasonable time. In case of default, Employer may employ and pay other agencies to amend and make good such defects and all expenses / damages / losses shall be recoverable by Employer or may be deducted from any money due to the contractor.

.....

Bid Document for Contract Package No. C#12A

IFB No. GWSP/LB/C#12A/2018-19/Date: 31.01.2019

**Contract Package No. C#12A:
Procurement of Works [Rate Contract] for providing Drinking water
House Service Connections**

SECTION II: BIDDING FORMS- TECHNICAL

Letter of Technical Bid

Bidder must prepare the Letter of Technical Bid with its letterhead showing the Bidder's name & address.

Date: *[insert date of Bid submission]*

Loan Agreement No.: *ID-P-201*

IFB No.: *GWSP/LB/C#12A/2018-19/Date: 31.01.2019*

To

Project Director,
Project Implementation Unit,
Saikia Commercial Complex, 2nd Floor, Christian Basti,
GS Road, Guwahati-781 005

Sir,

We, the undersigned, declare that:

- (a) We have examined and have no reservations to the Bidding Documents, including addenda issued.

[Insert the number and issuing date of each addendum];

- (b) We, meet the eligibility requirements of the Tender and We, have no conflict of interest.
- (c) We are not participating in more than one Bid in this bidding process, and we have not been temporarily suspended or debarred by the World Bank or blacklisted or suspended the Central or any State Government;
- (d) We have no conflict of interest in accordance with ITB 3;
- (e) We have experience and financial capabilities and hence, we are capable and offer to execute in conformity with the Bidding Documents the following Works:
Procurement of Works (Item rate) for Supply, Installation & Commissioning of Employer furnished D.I Pipes for the balance works under the Distribution Network in the DMA No. 5R6 of Ramsahill of South- Central Zone.
- (f) Our Bid shall be valid for a period of **forty five (45) days** from the date fixed for the Bid submission deadline in accordance with the Bidding Documents, and it shall remain binding upon us and may be accepted at any time before the expiration of that period;
- (g) If our Bid is accepted, we commit to obtain a Performance Security in accordance with the Bidding Documents;
- (h) We understand that this Bid, together with your written acceptance thereof included in your Letter of Acceptance, shall constitute a binding contract between us, until a formal contract is prepared and executed;
- (i) We understand that you are not bound to accept the lowest evaluated Bid or any other bid that you may receive; and
- (j) We hereby certify that we have taken steps to ensure that no person acting for us or on our behalf will engage in any type of fraud, corrupt, collusive, coercive, or obstructive practices; and will be strictly observe the laws against fraud and corruption in force in India, namely, "Prevention of Corruption Act 1988"

Name of the Bidder: *[insert complete name of person signing the Bid]*

Name of the person duly authorized to sign the Bid on behalf of the Bidder**[insert complete name of person duly authorized to sign the Bid]*

Title of the person signing the Bid *[insert complete title of the person signing the Bid]*

Signature of the person named above *[insert signature of person whose name and capacity are shown above]*

Date signed *[insert date of signing]* day of *[insert month]*, *[insert year]*

*: Person signing the Bid shall have the power of attorney given by the Bidder to be attached with Bid.

QUALIFICATION INFORMATION

1) IFB No.: GWSP/LB/C#12A/2018-19/Date: 31.01.2019

2) Name & Address of the Bidder:

Bidder's legal name:
Bidder's actual or intended year of incorporation:
Bidder's legal address: <i>[insert street/ number/ town or city]</i>
Bidder's authorized representative information Name Address: Telephone/Fax numbers: E-mail address:
Attach copies of original documents of: <input type="checkbox"/> Articles of Incorporation (or equivalent documents of constitution or association), and/or documents of registration of the legal entity named above.

1 For Individual Bidders

1.1 Principal place of business: _____

Power of attorney of signatory of Bid. **[Attach copy]**

1.2 Registered Civil Contractor with Assam PHED/ Assam PWD/ AUWSSB/ GMC/GMDA or if it is a manufacturer, ISI license for manufacturing PE Pipes & specials and GST Registration:
_____ **[Attach copy]**

1.3. Average Annual Turnover during the past 3 years [Bid requirement: Should have Minimum average Annual turnover of Rs. 1.50 crore, calculated as total certified payments received for contracts in progress or completed during the past 3 years, ie., from 1st April 2015.

Total value of Civil Engineering Construction work performed in the last Three years (in Rs. Lakhs). To support your claim also submit the Audited Balance Sheets and Auditor/Chartered Accountant's certificate.

Financial Year	Annual Turnover- Rs. in crore
	Single Entity
2015-16	
2016-17	
2017-18	
Average Annual Turnover	

1.4. Work Experience:

(a) A Civil contractor working for a municipality / Government Departments/ Undertakings in India and having experience during the last 3 years, from 1st April 2015 and Bid submission deadline, in Laying & jointing of DI/ PE/PPR/MS pipelines of at least **2 km**, for which the Bidder shall submit the credentials from the Employer, **or**

A Subcontractor, if he had worked under any Main Contractor for the ongoing JICA/JnNURM/ADB funded Water Supply Projects for Guwahati and having Experience during the last 3 years, from 1st April 2015 and Bid submission deadline, in Laying & jointing of DI/ PE/ PPR/ MS pipelines of at least 2 km, for which the Bidder shall submit the appropriate/required proof, such as the Work order, Contract and Proof of payment given by the main contractor.

Project Name	Name of Employer	Description of work- Diameter & Length of DI Pipes	Prime contractor or Sub-contractor	Contract No. & Date	Value of contract (Rs. Lakhs)	Stipulated period of completion	Actual date of completion*

* Enclose a certificate from the Engineer concerned for completion. If the Bidder is a Subcontractor, the Bidder shall submit the appropriate/required proof, such as the Work order, Contract and Proof of payment given by the main contractor.

(b) In case of a manufacturer, furnish the details in the two tables below, with supporting documents:

Year	Production of PE Pipes in m	Sales to Govt./Projects*	Sales to others, viz., Private
2015-16			
2016-17			
2017-18			
Total			

*In case of supplies to Govt./Projects, furnish the following details:

Project Name	Name of Employer	Diameter & Length of PE Pipes	Value of contract (Rs. Lakhs)	Stipulated period of completion	Actual date of completion

1.5. Minimum cash-flow: Demonstrate that you have access to, or availability of, financial resources such as liquid assets, unencumbered real assets, lines of credit, and other financial means, other than any contractual advance payments to meet: Rs.....Lakhs. [Minimum cash-flow requirement: INR 30 lakhs].

To support your claim also submit the Banker’s letter and other documents certified by the Company Auditor/ Chartered Accountant.

Evidence of access to financial resources to meet the requirements of working capital: cash in hand, lines of credit, etc. List them below and attach copies of support documents.

Name, address, and telephone, telex, and fax numbers of the Bidders’ bankers who may provide references if contacted by the Employer.

1.6. Information on litigation history in which the Bidder is involved.

Name of the work	Agreement number/date	Name & address of Employer	Contract Value in Rs	Cause of dispute	Amount Disputed	Remarks showing present status

Signature of the Bidder

Bid Document for Contract Package No. C#12A

IFB No. GWSP/LB/C#12A/2018-19/Date: 31.01.2019

**Contract Package No. C#12A:
Procurement of Works [Rate Contract] for providing Drinking water
House Service Connections**

SECTION III: BIDDING FORMS - FINANCIAL

Letter of Financial Bid

The Bidder must prepare the Letter of Financial Bid on its letterhead clearly showing the Bidder's complete name and address.

Date: *[insert date of Bid submission]*

Loan Agreement No.: *ID-P-201*

IFB No.: GWSP/LB/C#12A/2018-19/Date: 31.01.2019

To

Project Director,
Project Implementation Unit,
Saikia Commercial Complex, 2nd Floor, Christian Basti,
GS Road, Guwahati-781 005

Name of work: Contract Package No. C#12A- : Rate contract for providing Drinking Water House Service Connections in lots of 1,000 each for total of approximately 5,000 households in South-west & south-central Guwahati area, providing all the required goods & materials, install the Employer supplied Water meters, install the pipes & accessories, excavation and road restoration works all complete.

Sir,

We, the undersigned, hereby submit the Financial Bid including the Priced Bill of Quantities. In submitting our Financial Part we make the following additional declarations:

- 1) **Validity:** Our Bid shall be valid for the period of **45 days** from the deadline fixed for the Quotation submission;
- 2) We have examined the Instructions to Bidders, Scope of Works, Specifications, Drawings, Schedules, Conditions of Contract, Contract forms, Site Conditions and the attached Appendices and Addenda Nos. _____ for the above-named Contract.
- 3) We have understood and checked these documents and have ascertained that they contain no errors or other defects except as identified in our Tender. We accordingly offer to execute and complete the Works and to do testing, trial run and commission the facility for the period and in conformity with the terms and conditions contained in the Contract is for the total amount of:

Rs. _____ [in figures]

Rs. _____ [in words];

Yours faithfully,

Authorized Signature

Name & Title of Signatory _____

In the capacity of *[insert legal capacity of person signing the Letter of Quotation]*

Name of Bidder _____

Address _____

Dated on _____ day of _____, _____ *[insert date of signing]*

PREAMBLE TO PRICE SCHEDULE

Bill of Quantities for Rate contract for providing Drinking Water House Service Connections in lots of 1,000 each for total of approximately 5,000 households in South-west & south-central Guwahati area, providing all the required goods & materials, install the Employer supplied Water meters, install the pipes & accessories, excavation and road restoration works all complete

This Contract is for fixing rate contract for providing drinking water House Service Connections including supply of goods & materials, labour & allied services, excavation and road restoration works all complete.

- 1) The Contractor has to execute the work as per the Typical House service connection drawing provided along with the tender and has to provide Labour, materials and all allied services in connection with the execution of the works.
- 2) The Bill of quantities is for one Typical Lot of 1,000 Service Connections. Any Bidder may submit their Bids for maximum of 2 lots.
- 3) The Bill of quantities shall be read in conjunction with the Scope of Works, Technical Specifications, Conditions of contract and Drawings.
- 4) The Bidder is advised to examine all instructions, terms, specifications and other information in the Bid documents and consider and evaluate fully the price implications therein contained before filling the contract amount.
- 5) The Bidder should acquaint himself with the site conditions including the access to Work site.
- 6) There are, however, several minor items not specifically mentioned in the break-up (BOQ items), but shall be required to complete the job as per scope and specification of works stipulated in the tender document. The cost of such items shall deem to be distributed among the rates and prices entered for the related items.
- 7) The quoted rates in the Bill of Quantities shall, except insofar as it is otherwise provided under the Contract, include all Construction, labour, supervision, materials, erection, maintenance , insurance, profit, taxes and duties together with all general risks, liabilities and obligations set out or implied in the contract.
- 8) It shall be deemed that Bidder has included likely expenditure in his quoted price i.e., provision for field investigations, site clearance and final removal of all temporary works of whatsoever nature required for construction including, dewatering and availability of material of required quality etc., for the proper execution of works. The rates shall also be deemed to include any works and setting out that may be required to be carried out for all the works involved.
- 9) A rate shall be entered against each item in the Bill of Quantities, whether quantities are stated or not. The cost of items against which the contractor has failed to enter a rate shall be deemed to be covered under other rates and prices entered in the Bill of Quantities.
- 10) The quantities given in the Bill of Quantities are estimated and provisional and are given to provide a common basis for bidding. The basis of payment will be the actual quantities of work ordered and carried out, as measured by the Engineer (accepted by contractor) and valued at the rates and prices quoted in the priced bill of quantities.
- 11) All costs associated with testing, commissioning, inspection (except the Pre-delivery Inspection at the manufacturers' works by a Third Party if desired by the Employer) shall be deemed to be included in the items for the works, supply and installation.

-
- 12) The rates entered by the Bidder under the “Rate” and “Amount” columns in the Price Schedule, shall be the Bidder’s estimated rates for the item, inclusive of taxes and duties. The amount quoted by the Bidder including the taxes and duties will be considered for evaluation.
 - 13) Incomplete Bids shall be summarily rejected.

JICA Assisted Guwahati Water Supply project (ID - P201)

Supply and Installation of Goods and Materials for Providing Drinking Water House Service Connections for ONE LOT of 1,000 House Holds in South west Guwahati and South Central Guwahati Area.

BILL OF QUANTITY

Sl NO	Description	Unit	Qty	Rate - Rs.		Amount - Rs.			Remarks
				Basic	Taxes	Basic	Taxes	Total	
				a	b	c	d = a x b	e = a x c	
1	MATERIAL SUPPLY, DELIVERY AND STACKING								
1.1	Supply, delivery and stacking of Brass or any other suitable material ferrules conforming to PN 16 with 360° swivel and outlet at 90°. Including third party inspection, all taxes and duties, transportation, freight charges, loading and unloading, conveyance to the project site and stacking with cost of all labor and material as per direction of Employer's representative.		940						
a)	15 mm (1/2 inch)	Nos	755						
b)	20 mm (3/4 inch)	Nos	90						
c)	25 mm (1 inch)	Nos	65						
d)	32 mm (1 1/4 inch)	Nos	20						
e)	40 mm (1 1/2 inch)	Nos	5						
f)	50 mm (2 inch)	Nos	5						
1.2	Supply, delivery and stacking of Composite Saddle or DI Saddle to be clamped with Dry DI K9 pipes. Including third party inspection, all taxes and duties, transportation, freight charges, loading and unloading, conveyance to the project site and stacking with cost of all labor and material as per direction of Employer's representative.								
1.2.1	100mm (4 inch) N.B.	Nos	728						
a)	(100x15)mm / (4x 1/2)"	Nos	604						
b)	(100x20)mm / (4x 3/4)"	Nos	72						
c)	(100x25)mm / (4x 1)"	Nos	52						
1.2.2	150 mm (6 inch) N.B.	Nos	151						
a)	(150x15)mm / (6x 1/2)"	Nos	113						
b)	(150x20)mm / (6x 3/4)"	Nos	13						
c)	(150x25)mm / (6x 1)"	Nos	10						
d)	(150x32)mm / (6x 1 1/4)"	Nos	15						
1.2.3	200 mm (8 inch) N.B.	Nos	60						
a)	(200x15)mm / (8x 1/2)"	Nos	38						
b)	(200x20)mm / (8x 3/4)"	Nos	4						
c)	(200x25)mm / (8x 1)"	Nos	3						
d)	(200x32)mm / (8x 1 1/4)"	Nos	5						
e)	(200x40)mm / (8x 1 1/2)"	Nos	5						
f)	(200x50)mm / (8x 2)"	Nos	5						
1.3	Supply, delivery and stacking of Electrofusion Self-Tapping Tee for HDPE pipes with in-built cutter and coupler having Female threaded outlet. Including third party inspection, all taxes and duties, transportation, freight charges, loading and unloading, conveyance to the project site and stacking with cost of all labor and material as per direction of Employer's representative.		300						
a)	PE100 PN16 (110x20)mm (1/2 inch)	Nos	45						
b)	PE100 PN16 (110x25)mm (3/4 inch)	Nos	10						
c)	PE100 PN16 (110x32)mm (1 inch)	Nos	5						
1.4	Supply, delivery and stacking of Medium Density Polyethylene pipe (MDPE) conforming to ISO 4984 & ISO 4427 and manufactured from virgin resin of PE80 PN16. Compression fittings should have Raw material which is conforming BS 6920 and with moulded-in chrome plated brass/SS threaded insert outlet with thread dimension conforming to IS 554/ISO 7. Including third party inspection, all taxes and duties, transportation, freight charges, loading and unloading, conveyance to the project site and stacking with cost of all labor and material as per direction of Employer's representative.								
1.4.1	20 mm PE Pipe connections (1/2 inch)	Nos	800						
i	MDPE Pipes	mtr	4800						
ii	Compression Female threaded adapter with brass/SS threaded insert	Nos	800						
iii	Compression Male threaded adapter with brass/SS threaded insert	Nos	4000						
iv	Double compression elbow	Nos	2400						
1.4.2	25 mm PE Pipe connections (3/4 inch)	Nos	100						
i	MDPE Pipes	mtr	900						
ii	Compression Female threaded adapter with brass/SS threaded insert	Nos	100						
iii	Compression Male threaded adapter with brass/SS threaded insert	Nos	500						
iv	Double compression elbow	Nos	300						
1.4.3	32 mm PE pipe connections (1inch)	Nos	70						
i	MDPE Pipes	mtr	630						
ii	Compression Female threaded adapter with brass/SS threaded insert	Nos	70						
iii	Compression Male threaded adapter with brass/SS threaded insert	Nos	350						
iv	Double compression elbow	Nos	210						
1.4.4	40 mm PE Pipe connections (1 1/4 inch)	mtr	20						
i	MDPE Pipes	mtr	180						
ii	Compression Female threaded adapter with brass/SS threaded insert	Nos	20						
iii	Compression Male threaded adapter with brass/SS threaded insert	Nos	100						
iv	Double compression elbow	Nos	60						
1.4.5	50 mm PE Pipe connections (1 1/2 inch)	Nos	5						
i	MDPE Pipes	mtr	25						
ii	Compression Female threaded adapter with brass/SS threaded insert	Nos	5						
iii	Compression Male threaded adapter with brass/SS threaded insert	Nos	25						

JICA Assisted Guwahati Water Supply project (ID - P201)

Supply and Installation of Goods and Materials for Providing Drinking Water House Service Connections for ONE LOT of 1,000 House Holds in South west Guwahati and South Central Guwahati Area.

BILL OF QUANTITY

Sl NO	Description	Unit	Qty	Rate - Rs.		Amount - Rs.			Remarks
				Basic	Taxes	Basic	Taxes	Total	
				a	b	c	d = a x b	e = a x c	
iv	Double compression elbow	Nos	15						
1.4.6	63 mm PE Pipe connection (2 inch)	Nos	5						
i	MDPE Pipes	mtr	25						
ii	Compression Female threaded adapter with brass/SS threaded insert	Nos	5						
iii	Compression Male threaded adapter with brass/SS threaded insert	Nos	25						
iv	Double compression elbow	Nos	15						
1.5	Supply, delivery and stacking of Compression End UPVC Ball Valve PN 16 rating (or any other material conforming BS 6920) with one end compression fitting and the other end with female thread conforming to ISO:4422-4 and ISO:7/BS:21/IS:554, etc. (Outer Diameter is considered). Including third party inspection, all taxes and duties, transportation, freight charges, loading and unloading, conveyance to the project site and stacking with cost of all labor and material as per direction of Employer's representative.								
i	20 mm	Nos	800						
ii	25 mm	Nos	100						
iii	32 mm	Nos	70						
iv	40 mm	Nos	20						
v	50 mm	Nos	5						
vi	63 mm	Nos	5						
1.6	Supply, delivery and stacking of GI pipe with necessary specials Class "B" conforming to IS 1239. Including third party inspection, all taxes and duties, transportation, freight charges, loading and unloading, conveyance to the project site and stacking with cost of all labor and material as per direction of Employer's representative.								
a)	50 mm	mtr	500						
b)	80 mm	mtr	75						
1.7	Supply, delivery and stacking of Cast iron Y-type strainer (ID). Including third party inspection, all taxes and duties, transportation, freight charges, loading and unloading, conveyance to the project site and stacking with cost of all labor and material as per direction of Employer's representative.								
i	15 mm (1/2 inch)	Nos	800						
ii	20 mm (3/4 inch)	Nos	100						
iii	25 mm (1 inch)	Nos	70						
iv	32 mm (1 1/4 inch)	Nos	20						
v	40 mm (1 1/2 inch)	Nos	5						
vi	50 mm (2 inch)	Nos	5						
1.8	Supply, delivery and stacking of Pressure Reducing Valve (PRV) of rating PN 16 /0.8, made of Brass or Bronze or any suitable material as per BS EN 1567:2000 (ID). Including third party inspection, all taxes and duties, transportation, freight charges, loading and unloading, conveyance to the project site and stacking with cost of all labor and material as per direction of Employer's representative.								
i	15 mm (1/2 inch)	Nos	800						
ii	20 mm (3/4 inch)	Nos	100						
iii	25 mm (1 inch)	Nos	70						
iv	32 mm (1 1/4 inch)	Nos	20						
v	40 mm (1 1/2 inch)	Nos	5						
vi	50 mm (2 inch)	Nos	5						
1.90	Supplying of HDPE (PE100, PN16) pipe including all specials confirming to IS 4984 and the specifications, including third party inspection, all taxes and duties, transportation, freight charges, loading and unloading, conveyance to the project site and stacking with cost of all labor and material as per direction of Employer's representative.								
i	63 mm HDPE Pipe	mtr	100						
ii	110mm HDPE Stubend with Annular Ring / Flange with Bolts each connections	Nos	2						
1.10	Supply of Electrofusion Self-Tapping Tee for HDPE pipes with in-built cutter and coupler having Female threaded outlet . Including third party inspection, all taxes and duties, transportation, freight charges, loading and unloading, conveyance to the project site and stacking with cost of all labor and material as per direction of Employer's representative.								
i	(63x15)mm	Nos	20						
1.11	Supply of Cast iron Y-type strainer as per directions of Employer's Representative (ID). Including third party inspection, all taxes and duties, transportation, freight charges, loading and unloading, conveyance to the project site and stacking with cost of all labor and material as per direction of Employer's representative.	Nos	20						
1.12	Supply, delivery and stacking of Water Meter Box made of PE/PP/Thermostating Plastic. Including third party inspection, all taxes and duties, transportation, freight charges, loading and unloading, conveyance to the project site and stacking with cost of all labor and material as per direction of Employer's representative.	Nos	1000						
2	Earth Work								

JICA Assisted Guwahati Water Supply project (ID - P201)

Supply and Installation of Goods and Materials for Providing Drinking Water House Service Connections for ONE LOT of 1,000 House Holds in South west Guwahati and South Central Guwahati Area.

BILL OF QUANTITY

Sl NO	Description	Unit	Qty	Rate - Rs.		Amount - Rs.			Remarks
				Basic	Taxes	Basic	Taxes	Total	
				a	b	c	d = a x b	e = a x c	
2.1	Earth work for excavation of foundations, pipe trenches, valve chambers, thrust blocks, masonry work, etc. in all kinds of ordinary soils such as murum, sand, sandy silt, clay, kankar etc, including backfilling, dressing, compaction of the bottoms of the excavation, shoring and strutting wherever required, dewatering whenever required, removal of the excavated soil, stockpiling and disposal of surplus excavated soil off-site as directed by the Employer's Representative.								
i)	0 to 1.5 m from GL	Cu.m	2178						
ii)	above 1.5 m to 3.0 m depth from GL	Cu.m	233						
2.2	Earth work for excavation of foundations, pipe trenches, valve chambers, thrust blocks, masonry work, etc. in all kinds of ordinary rock and hard rock (blasting prohibited), RCC etc, including backfilling dressing, compaction of the bottoms, shoring and strutting wherever required, dewatering whenever required, removal of the excavated rock, stockpiling and disposal of surplus excavated rock off-site as directed by the Employer's Representative.								
i)	0 to 1.5 m from GL	Cu.m	934						
3	FITTING AND INSTALLATION								
3.1	Fitting & Fixing of Brass or any other suitable material ferrules, conforming to PN 16 with 360° swivel and female threaded outlet at 90°, after installation of saddles (dry) after drilling and tapping the K9 DI pipe. This item includes transportation from the storeyard to the project site, stacking as per BIS requirements, loading, unloading, hoisting, lowering, marginal cutting and grinding wherever necessary, assembling, jointing, providing temporary supports etc, all complete with approved equipment and as per directions of Employer's Representative								
3.1.1	100 mm	Nos	728						
i	100x15	Nos	604						
ii	100x20	Nos	72						
iii	100x25	Nos	52						
3.1.2	150 mm	Nos	152						
i	150x15	Nos	113						
ii	150x20	Nos	14						
iii	150x25	Nos	10						
iv	150x32	Nos	15						
3.1.3	200 mm	Nos	61						
i	200x16	Nos	38						
ii	200x20	Nos	5						
iii	200x25	Nos	3						
iv	200x32	Nos	5						
v	200x40	Nos	5						
vi	200x50	Nos	5						
3.2	Fitting & Fixing of Electrofusion Self-Tapping Tee for HDPE pipes with in-built cutter and coupler having Female threaded outlet. This item includes transportation from the storeyard to the project site, stacking as per BIS requirements, loading, unloading, hoisting, lowering, marginal cutting and grinding wherever necessary, assembling, jointing, providing temporary supports etc, all complete with approved equipment and as per directions of Employer's Representative								
a)	(110x20)mm	Nos	45						
b)	(110x25)mm	Nos	10						
c)	(110x32)mm	Nos	5						
3.3	Fitting and fixing of MDPE pipes along with all the compression fittings and compression end UPVC Ball Valve (or any other material conforming BS 6920) with necessary fittings etc. This item includes transportation from the storeyard to the project site, stacking as per BIS requirements, loading, unloading, hoisting, lowering, marginal cutting and grinding wherever necessary, assembling, jointing, providing temporary supports etc, all complete with approved equipment and as per directions of Employer's Representative (Outer Diameter is considered)								
i	20 mm	Nos	800						
ii	25 mm	Nos	100						
iii	32 mm	Nos	70						
iv	40 mm	Nos	20						
v	50 mm	Nos	5						
vi	63 mm	Nos	5						
3.4	Laying of GI pipe and necessary fittings across drains & culverts. This item includes transportation from the storeyard to the project site, stacking as per BIS requirements, loading, unloading, hoisting, lowering, marginal cutting and grinding wherever necessary, assembling, jointing, providing temporary supports etc, all complete with approved equipment and as per directions of Employer's Representative								
i	50 mm	mtr	500						
ii	80 mm	mtr	75						

JICA Assisted Guwahati Water Supply project (ID - P201)

Supply and Installation of Goods and Materials for Providing Drinking Water House Service Connections for ONE LOT of 1,000 House Holds in South west Guwahati and South Central Guwahati Area.

BILL OF QUANTITY

Sl NO	Description	Unit	Qty	Rate - Rs.		Amount - Rs.			Remarks
				Basic	Taxes	Basic	Taxes	Total	
				a	b	c	d = a x b	e = a x c	
3.5	Fitting and fixing of Cast iron Y-type strainer as This item includes transportation from the storeyard to the project site, stacking as per BIS requirements, loading, unloading, hoisting, lowering, marginal cutting and grinding wherever necessary, assembling, jointing, providing temporary supports etc, all complete with approved equipment and as per directions of Employer's Representative (ID)								
i	15 mm (1/2 inch)	Nos	780						
ii	20 mm (3/4 inch)	Nos	100						
iii	25 mm (1 inch)	Nos	70						
iv	32 mm (1 1/4 inch)	Nos	20						
v	40 mm (1 1/2 inch)	Nos	5						
vi	50 mm (2 inch)	Nos	5						
3.6	Fitting & Fixing of Pressure Reducing Valve (PRV) This item includes transportation from the storeyard to the project site, stacking as per BIS requirements, loading, unloading, hoisting, lowering, marginal cutting and grinding wherever necessary, assembling, jointing, providing temporary supports etc, all complete with approved equipment and as per directions of Employer's Representative (ID)								
i	15 mm (1/2 inch)	Nos	780						
ii	20 mm (3/4 inch)	Nos	100						
iii	25 mm (1 inch)	Nos	70						
iv	32 mm (1 1/4 inch)	Nos	20						
v	40 mm (1 1/2 inch)	Nos	5						
vi	50 mm (2 inch)	Nos	5						
3.7	Handling,aligning,laying and jointing of PN10 HDPE (PE80) pipes with specials by butt welding/spigot joints conforming to IS and specifications. The item includes transportation of pipes and specials from store yard to site, stacking of pipe asper BIS, loading, unloading, hoisting, lowering, cutting and grinding wherever necessary, assembling, jointing, providing temporary supports etc., allcomplete with approved equipment, for pipes of following diameter. Conforming to IS 4984 as per directions of Employer's Representative								
i	63mm	mtr	100						
3.8	Fitting and fixing of Consumer Water meters with necessary fittings of respective dia as well as Fitting & Fixing of Water Meter Box Enclosure made of PE/PP/Thermostating plastic. This item includes transportation from the storeyard to the project site, stacking as per BIS requirements, loading, unloading, hoisting, lowering, marginal cutting and grinding wherever necessary, assembling, jointing, providing temporary supports etc, all complete with approved equipment and as per directions of Employer's Representative (ID)								
i	15 mm (1/2 inch)	Nos	800						
ii	20 mm (3/4 inch)	Nos	100						
iii	25 mm (1 inch)	Nos	70						
iv	32 mm (1 1/4 inch)	Nos	20						
v	40 mm (1 1/2 inch)	Nos	5						
vi	50 mm (2 inch)	Nos	5						
3.9	Making bore hole horizontally across road for crossing service connection pipeline including fitting of GI casing pipe of required diameter. This item includes transportation from the storeyard to the project site, stacking as per BIS requirements, loading, unloading, hoisting, lowering, marginal cutting and grinding wherever necessary, assembling, jointing, providing temporary supports etc, all complete with approved equipment and as per directions of Employer's Representative.								
i	50 mm	Mtr	75						
ii	80 mm	Mtr	50						
4	Hydro Testing								
4.1	Hydraulic testing of the House Service Connection line comprising of MDPE with other accessories like Ball Valve,Y Type Strainer,PRV,Water Meter etc., for the following diameters at the required test pressure. This item includes cost of water, labour, pumping etc., as per specifications and as directed by the Employer representative.								
i	upto 32mm	Mtr	6330						
ii	above 32mm to upto 63mm	Mtr	230						
4.2	Hydraulic testing of the House Service Connection line comprising of HDPE with other accessories like Ball Valve,Y Type Strainer,PRV,Water Meter etc., for the following diameters at the required test pressure. This item includes cost of water, labour, pumping etc., as per specifications and as directed by the Employer representative.								
i	63 mm	Mtr	100						
5	Drilling & Tapping machine for DRY DI pipes, as per technical specifications in the tender document.	Nos	1						
6	Electro fusion Welding Machine with 1 litre PE pipe cleaner and 10 manual pipe peeler/scrapper as per technical specifications in tender document.	Nos	1						

JICA Assisted Guwahati Water Supply project (ID - P201)

Supply and Installation of Goods and Materials for Providing Drinking Water House Service Connections for ONE LOT of 1,000 House Holds in South west Guwahati and South Central Guwahati Area.

BILL OF QUANTITY

Sl NO	Description	Unit	Qty	Rate - Rs.		Amount - Rs.			Remarks
				Basic	Taxes	Basic	Taxes	Total	
				a	b	c	d = a x b	e = a x c	
7	Road Restoration as required by the concerned Authority and as directed by Employer's Representative								
i	Providing and laying of Prime Coat, as per specification and drawing and as directed	Sq.m	505						
ii	Providing and laying of Semi dense bituminous concrete (SDBC), as per specification and drawing and as directed	Cu.m	6						
iii	Providing and laying of Tack coat (TC), as per specification and drawing and as directed	Sq.m	505						
iv	Providing and laying of Bituminous macadam (BM), as per specification and drawing and as directed	Cu.m	25						
v	Providing and laying of Premix carpet (PC), as per specification and drawing and as directed	Sq.m	505						
vi	Reconstruction of WBM Roads : Providing, laying, spreading and compacting stone aggregates of specific sizes as per specification and drawing to water bound macadam including spreading in uniform thickness, hand packing, rolling with vibratory roller 8-10 tones in stages to proper grade and camber, applying and brooming requisite type of stone screenings & binding material, and completer as per specification and drawing and as directed	Cu.m	45						
vii	Reconstruction of Concrete Roads : Providing, placing and finishing Cement Concrete roads to match the existing roadway which was removed, as directed by the Employer's Representative . Grade M20 concrete shall be used and placed to the same depth as the existing roadway surface. A screeded finish shall be applied.	Cu.m	10						
viii	Providing and laying of bricks on edge for road restoration on earth subgrade. The bricks shall be on edge, diagonally placed, and gap filled up with sand, all complete, as per specification and drawings.	Sq.m	102						
ix	Providing and laying of interlocking concrete block pavement(ICBP) having thickness 80 mm as per IS:15658-2006(Compressive strength 47.20N/mm.Sq.), all complete, as per specification and drawings.	Sq.m	64						
8	Miscellaneous Civil Work								
8.1	Dismantling Work including dressing, compaction of the bottoms, shoring and strutting wherever required, dewatering whenever required, removal of the excavated material, stockpiling and disposal of surplus excavated material off-site as directed by the Employer's Representative.								
i	Bituminous Layer (BM/BT)	Cu.m	42						
ii	Water Bound Macadam Layer (WBM)	Cu.m	48						
iii	Granular Layer	Cu.m	51						
iv	Plain Cement Concrete (P.C.C)	Cu.m	30						
v	Interlocking Concrete Paver Block (ICPB)	Sq.m	64						
vi	Brick Soling (BS)	Sq.m	102						
8.2	Brick Masonry Work								
	Construction of Brick Masonry for sub/superstructure of 115 mm thick walls using cement mortar with a cement to sand ratio of 1:4. This item includes the cost of transportation of all materials, labor, scaffolding, curing etc. as per specifications and drawings and as directed by the Employer's Representative. This is Work not included in Item 6.	Sq.m	11						
8.3	Plastering Work								
(a)	Providing and applying cement sand plaster 12 mm thick in a single coat using cement mortar with a cement to sand ratio of 1:4 without near finish to concrete or brick surfaces including scaffolding and curing as directed by the Employer's Representative. This is Work not included in Item 6.	Sq.m	10						
(b)	Providing and applying cement sand plaster 20 mm thick in a single coat using cement mortar with a cement to sand ratio of 1:4 without near finish to concrete or brick surfaces including scaffolding and curing as directed by the Employer's Representative. This is Work not included in Item 6.	Sq.m	12						
8.4	Reinforced Cement Concrete Work								
	Providing and placing reinforced cement concrete (RCC) of one of the following grades with 10-20 mm stone aggregate (crusher broken) including shuttering and staging, curing etc. Including precast cover slab for chamber wherever required, as per the specifications and drawings and as directed by the Employer's Representative.								
(a)	Grade M25 concrete	Cum	2.00						
8.5	Providing Steel reinforcement (Thermo-Mechanically Treated bars of grade Fe-500D or more) for R.C.C. work including straightening, cutting, bending, placing in position and binding including binding wire all complete upto plinth level, as per the specifications and drawings and as directed by the Employer's Representative.	Kg	50.00						
	Grand Total for (Item No. 01 to 08)								

JICA Assisted Guwahati Water Supply project (ID - P201)

Supply and Installation of Goods and Materials for Providing Drinking Water House Service Connections for ONE LOT of 1,000 House Holds in South west Guwahati and South Central Guwahati Area.

BILL OF QUANTITY

SI NO	Description	Unit	Qty	Rate - Rs.		Amount - Rs.			Remarks
				Basic	Taxes	Basic	Taxes	Total	
				a	b	c	d = a x b	e = a x c	
Rupees in words.....									
									Signature of the Bidder

SECTION: IV: SCOPE OF WORK

Rate contract for providing Drinking Water House Service Connections in lots of 1,000 each- for total of approximately 5,000 households in South-west & south-central Guwahati area, providing all the required goods & materials, install the Employer supplied Water meters, install the pipes & accessories, excavation and road restoration works all complete

Project Background

The Guwahati Metropolitan Area has been divided into four distribution zones for water supply, namely (1) South East, (2) South Central, (3) South West, all located south of the Brahmaputra River and (4) North Guwahati on the northern bank of the Brahmaputra River.

At present, there are three agencies which provide water supply in the City of Guwahati, namely the Guwahati Municipal Corporation, Public Health and Engineering Department (PHED), and Assam Urban Water Supply & Sewerage Board (AUWSSB). Of the three agencies the GMC covers about 30% of the population in this city. Most of the water treatment and supply facilities have outlived their lives as a result of a budget deficiency for repair or replacement.

The Master Plan for the Guwahati Metropolitan Area 2025 sets the target of “100% houses will be supplied with piped filtered water by the year 2025”. The on-going water supply project for the South West Zone is being taken up under Jawaharlal Nehru National Urban Renewal Mission (JNNURM) funding. The water supply for South East Zone is being planned under the Asian Development Bank’s (ADB’s) assistance.

The water supply zones under the Japanese International Cooperation Agency (JICA) funding for this Contract (ID-P 201) are the South Central and North Zones. The South Central Zone is the center of the city with the highest population among the four zones. This project will receive a loan assistance of 29,453 million Japanese Yen. The loan will fund civil works for constructing water supply facilities, procurement of machinery and equipment, and consulting services.

This Guwahati Water Supply Project (GWSP) aims to construct water treatment, conveyance and storage facilities in the South Central and Northern parts of the city to activate a potable water supply system with 100% coverage of the citizens within the above areas and thus leading to upgrading the citizen’s living standard.

Project Objectives

This project intends to improve living conditions in the rapidly growing Guwahati area, by providing new water supply facilities.

The main objective of Japanese loan assistance is to support India in establishing physical infrastructure to boost and sustain economic growth. At the same time, Japanese assistance seeks to support India’s efforts to alleviate poverty. In keeping with these goals, the loan package strategically covers this water supply project.

Project Description

The Guwahati Water Supply Project, (ICA Loan No.ID-P 201) has been structured to progressively develop the water supply facilities in a phased manner in order to meet the ever increasing water demands of the South Central and North Zones. The GWSP has been planned to be implemented in two (2) phases. Phase 1 will be designed to accommodate the projected year 2025 water demands and Phase 2 the projected year 2040 water demands. The transmission and distribution piping works under Phase I will be implemented to accommodate the demand of Phase 2.

Works under Contract Package C-1 and C-03 include: Intake, Water Treatment Plant and Clear Water Reservoir cum Pumping Station for North zone and South Central zone respectively.

Works under the Contract Package (C-04) for the South Central Zone facilities include: the construction of a main and seven service reservoirs, service buildings with booster chlorination facilities at all of the reservoir sites, the construction of booster pump stations, the supply and installation of MS and DI transmission mains etc.

Distribution networks installation works are included under Contract Packages: 2, 5, 6 & 7. The DI pipes to be installed under these Contracts (C- 02, 05, 06, 07) will be supplied by the PIU.

Providing House Service Connections:

Implementation of the projects is now underway, works are in different stages and partial commissioning of the project is scheduled for completion in phases from February 2019.

To ensure long-term sustainability of the water supply systems, it is critical that proper house service connections along with accurate and efficient water metering and billing systems to be provided to ensure proper customer services and for the recovery of operating and maintenance costs from water customers.

The House Service Connection work is being implemented by the Project Implementation Unit (PIU). Government of India has received loan from Japan International Cooperation Agency (JICA) under the loan ID-P-201 for the Guwahati Water Supply Project (GWSP) and it intends to apply part of the proceeds of this loan to payments for Procurement of works [Rate Contract] for providing drinking water House Service Connections.

Scope of Works

This is a single–point responsibility Rate contract for providing Drinking Water House Service Connections in lots of 1,000 each for total of approximately 5,000 households in South-west & south-central Guwahati area, providing all the required goods & materials, install the Employer supplied Water meters, install the pipes & accessories, excavation and road restoration works all complete in the south-West and South-central Guwahati. The following is the scope of work of this tender.

- 1.1. The scope of work needs to be read in conjunction with the technical specifications provided in the Technical Specification section of this document. All rates and prices entered in the Schedule of Work shall be deemed to have included the following scope of works, but not limited to and shall cover all associated costs related to the item of work:
- 1.2. The Employer intends to complete the entire work of providing 5,000 House Service Connections, within 3 months' time. On finalizing the Rate contract, Employer will issue Work orders for 1,000 connections [considered as one 'Lot'] to the lowest evaluated bidders and sign the contract and assign the areas to work.
- 1.3. Before signing the contract, the successful Bidders/Contractors shall submit the Performance Security amounting to 10% of the Value of Work order for one each lot of 1,000 connections.
- 1.4. Upon completion of one lot or if the Contractor mobilizes more 'teams' of labour and on payment of Performance Security of 10% of the Value of Work order for another lot of 1,000 connections, the Work order for the next 1,000 connections will be issued and so on.
- 1.5. The decision of the Employer in terms of appointment of Contractors and allotment of Work and extending the time will be final and binding on all Contractors.
- 1.6. The list of Consumers for providing House Service Connections, area wise / DMA wise, as deemed appropriate by the Employer or Employer's Engineer will be provided, progressively over the period of the contract. The contractor has to plan and implement the work including its procurement. However prior approval of the Employer will be required before starting the HSC work in any area / DMA.
- 1.7. The Contractor has to be in touch with the consumers for providing the connections and have to implement the work with minimum inconvenience to the consumers. After completion of the work, the prescribed 'Work Completion Form' and the measurements accepted by the contractor, need to be certified by the Engineer's representative. These shall be submitted along with the Interim Payment

Certificate, which will be the basis for release of payment.

- 1.8. The Contractor shall be responsible for Construction, maintenance and removal, if required, of temporary site drainage on the Site, and for ensuring that all drains are kept clear of debris and blockages at all times.
- 1.9. The Contractor has to execute the work as per the Typical House service connection drawing provided along with the tender and has to provide all the required goods & materials, install the Employer supplied Water meters, install the pipes & accessories, excavation and road restoration works all complete services in connection with the execution of the works.
- 1.10. The Contractor will be responsible for the crossing of any open or closed drains, channels, and roads, providing GI Pipe casing and restoring the drains to the original condition, if any damage is caused.
- 1.11. Wherever required, the Contractor has to provide HDPE PN 16 Header pipes, with the required specials, in the by-lanes, as instructed by the Engineer.
- 1.12. The Service connection from the D.I Pipeline should be secured firmly by providing a Swivel Banjo Ferule and Strap Saddle. Fixation of ferrules are to be done using Drilling and Tapping machines only. Making holes in DI pipes through any other method like chiseling etc. is strictly prohibited.

Drilling and Tapping Machines that are required for installation of ferrule connections has been included in the Bill of Quantities, which shall be quoted by the Bidder and returned to the Employer by the contractor on completion of works.

The connection from HDPE Pipeline should be made by providing an Electro Fusion Tapping Tee with inbuilt cutter.

All the Service connections will be given by providing MDPE PE 80 Blue Pipes conforming to ISO 4427 for conveyance of Potable water for Human Consumption and manufactured from virgin natural resin PE 80 food grade compounded raw material, containing those anti – oxidants, UV Stabilizers & Pigments necessary for manufacturing of pipes. Electro fusion Welding Machine that is required for installation of Electro Fusion Tapping Tee shall be provided by the Contractor at his own cost.

- 1.13. For all the house service connections, the compression end UPVC Ball Valve or of any other material conforming to BS 6920, Cast Iron Y-Strainer and Pressure Reducing Valve conforming to BS EN 1567:2000 should be fixed on the connection before the meter point. The Contractor shall fix the Water Meter that will be provided by the Employer. The compression fittings PN 16 rated shall be conforming to ISO 14236 and its latest versions, etc., for crossing of any open or closed drains, channels, GI Pipe casing shall be provided.
- 1.14. The jurisdiction of the contractor starts from the distribution mains ferrule point to the meter point (1 meter) within the consumer premises. The consumer meter that will be supplied by the Employer will be installed and Ball Valve/Stop Cock, Y-Strainer, PRV will be provided by the Contractor within the consumer premises. The plumbing work beyond the meter point within the consumer premises will not fall under the jurisdiction of this contract and will be taken up by the individual consumer.
- 1.15. The Contractor has to supply Goods/Material required for the work and has to bear transportation, which shall include for all labour and equipment required for unpacking, loading, conveying, unloading, storing, and multiple handling of all and every item to be transported. The Contractor is responsible for storage and safe custody of the materials supplied by him for this work and also the Water Meters supplied by the Employer.
- 1.16. The Consumer Water Meters are to be supplied by the Employer and to be fixed by the Contractor. All other materials required for completing the work, such as Swivel Banjo Ferule & Strap Saddle for tapping from D.I. Pipes, Electro Fusion Tapping Tee with inbuilt cutter for tapping from HDPE Pipes, MDPE PE 80 Blue Pipes (sizes varying from 20mm to 63mm dia.) conforming to ISO 4427, UPVC Ball Valve PN16 or any other material conforming to BS 6920, Pressure Reducing Valve PN 16 conforming to BS EN 1567:2000, compression fittings PN 16 rated conforming to ISO 14236, GI Pipe casing, HDPE pipes and HDPE fittings etc., conforming to Indian or its equivalent standards shall be provided by the Contractor.

- 1.17. The Contractor needs to provide 12 months warranty of the materials supplied as a part of the contract which includes House Service Connection Pipes, fittings, Ball valves, Y-Strainer, PRV's, etc.,
- 1.18. Factory Acceptance Test shall be carried out by the contractor/supplier and the Test Reports shall be submitted to the Employer or his representative.
- 1.19. The Employer reserves the right to appoint Third party inspection agencies at the manufacturers' premises. In such case, the inspection fee will be borne by the Employer.
- 1.20. The Contractor shall employ only the licensed Plumbers of the Guwahati Metropolitan Drinking Water & Sewerage Board [GMDWSB] or the Plumbers who were trained by the GMDWSB / PIU or qualified plumbers, who have general hands-on experience of plumbing works in municipal water supply system and whose credentials are to be got approved from the Employer's representative. Periodic competence shall be tested and those found incompetent shall be removed from the job.
List of Plumbers trained the GMDWSB / PIU is appended.
- 1.21. All temporary works required for installation, testing and commissioning of the house service connection, for example excavation, backfilling, reinstatement, dewatering, providing valves and capping-off all works complete as per the applicable IS provisions, are to be executed by the contractor.
- 1.22. The Contractor has to liaise with the Pipeline Contractor for charging of the lines for conducting testing and commissioning of the House Service Connections.
- 1.23. The Contractor should undertake reinstatement of the roads, drains and also within the consumer premises as per the Engineer's requirement and to the satisfaction of the consumer. The reinstatement within the consumer premises are to be made to a reasonable extent, up to the meter point and however, it will be limited to maximum of cement concrete (CC) flooring irrespective of the type of flooring (marble / granite, etc.,) prevalent at the start of the work. In order to avoid dispute in this regard the contractor has to take pre and post work photographs of the flooring within consumer premises, for record purpose and to prevent potential dispute, if any.
- 1.24. All general obligations, liabilities and risks involved in the execution and maintenance of the Works set forth are reasonably implied in the documents on which the Tender is based.
- 1.25. All works in isolating and emptying existing mains and the satisfactory disposal of water is the responsibility of the contractor, in coordination with the pipeline contractor.
- 1.26. No separate payment for dewatering will be made. The required dewatering at site is to be done by the Contractor to prevent water logging and contamination. The cost of dewatering is to be included in the rates for items quoted by the Bidder.
- 1.27. Traffic management: Contractor should provide adequate safety barricades / tapes, warning lights to ensure public safety while executing the work.
- 1.28. The contractor has to obtain road cutting permissions from the respective Departments. However assistance will be provided by the Employer in facilitating this.
- 1.29. The contractor has to provide prior intimation to traffic police and the concerned Utility Departments, wherever road cutting and service connection work will be taken up so as to minimize the public inconvenience.
- 1.30. The contractor also need to provide prior intimation to the consumers before taking up service connection work to his premises.
- 1.31. The Contractor shall take into account in his work program and contract rates, the effect of water availability limitations, availability of fronts for installation of house service connections on his activities, and no extra claims or extensions of time will be considered as a result of any delays or postponement of work for this reason.
- 1.32. Any other work which is required to be done and has relation with respect to the supply and installation work done by the contractor during the works contract period need to be undertaken.

SECTION: V: TECHNICAL SPECIFICATIONS

1. 360° Swivel Banjo Ferrule:

Swivel Ferrule for water services shall be as per certification of Indian Standard or any other equivalent standards for application in drinking water supply DI pipes conforming to PN 16 bar. It should be a draw off appliance with a vertical inlet for screwing on to water main and a horizontal outlet.

Ferrules shall be standard screw down pattern brass or any other suitable material with female BSP (British Standard Pipe) screwed single outlet with suitable thread for the purpose. It shall have a main stem with 360° swivel (rotate) outlet at 90° with control of water flow via a threaded inner plug.

The ferrule shall be designed for underground installation and to handle potable water with temperature up to 50° C and also to withstand a working pressure of 16 kg/cm². Every ferrule including the component parts should be hydraulically tested for 20 kg/cm² adopting the suitable test procedure and should ensure the leak free operation while installed. The design of ferrule shall permit the installation of service pipe by means of drilling and tapping machine both under pressure and dry and with service saddles into DI pipes of different diameters.

The material of the stem banjo, inner plug and top cap shall be brass or any other suitable material, conforming to IS 3004. The material of banjo washer and top cap washer shall be polypropylene or nitrile rubber and rubber shall provide the sealing between outer body and the ferrule stem. The ingress of dirt shall be prevented by a polypropylene top plug. The name or trade mark of manufacturer and size of the ferrule shall be permanently marked on the body of ferrule.

Every ferrule including the component parts should be hydraulically tested for PN 20 bar adopting the suitable test procedure and should ensure the leak free operation while installed.

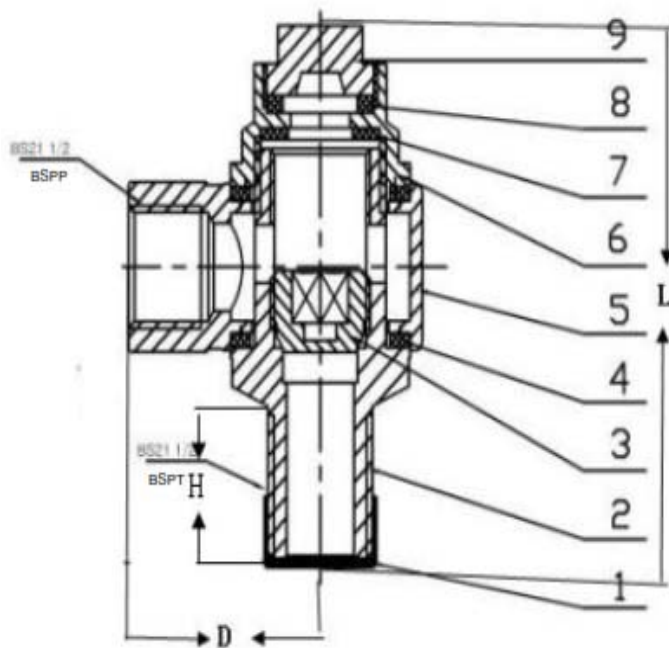

Material of Construction:

Sr. No.	Description	MOC	Qty.
1	Plastic Cover	PVC	1
2	Stem	Brass	1
3	Inner Plug	Brass	1
4	Banjo Washer	EPDM	2
5	Banjo	Brass	1
6	Top Cap	Brass	1
7	Top Cap Washer	EPDM / NBR	1
8	Rubber Washer	PTEF	1
9	Top Plug	Brass	1

Dimensions:

Size of Swivel Brass Ferrule	Length – L (mm)	Diameter - D (mm)	Height – H (mm)
D ½"	95	37	24
D ¾"	96	42	24
D 1"	107	47	26

2. Strap Saddles for DI Pipes:

Strap Saddles to be provided for DI Pipes as per IS or ISO or equivalent standard for providing service connections.

- (i) **Composite Strap Saddle:** Composite Strap Saddle for service connection on Ductile Iron water distribution mains shall be of wrap around design and wide skirt for proper support which provides excellent stability to the saddle and reinforce the pipe.

Composite Strap Saddle Fittings manufacturers must have ISO 9001/ ISO 14000/ ISO 18001 certification for their QMS, EMS & OHSS systems. It shall be suitable for maximum working pressure 16 bar (kg/cm²). Manufacturer specification, Quality assurance plan (QAP) to be submitted by the respective bidder for the client/ consultant approval.

Composite Strap Saddle should have moulded-in chrome plated brass female threaded insert outlet to connect necessary fittings. Thread dimension shall be compatible for using drill machine and tool for cutting through the mains. Adequate thickness should be provided to hold brass insert in place and avoid leakage while pressure applications. The EPDM seal shall sustain maximum working pressure of 16 bar and show no leaks. The composite strap saddle shall be designed such that the tapping tool kit fit perfectly on the metallic insert of the composite strap saddle in order to drill the pipe with the saddle already fitted.

Material of Construction:

Body: Body of Composite DI Saddle to be manufactured by injection moulding using virgin compounded PE 80 OR PE 100 OR PP Blue polymer with Stainless steel SS 304 grade stirrup plate and shall be duly embedded, except at the place of fastener. With a melt flow rate between a melt flow rate between 0.2 – 1.4 grams/10 minutes and should comply with requirements of BS 3412 and/or BS EN 12201-1.

Strap: Saddle wrap/strap shall be Stainless Steel to prevent corrosion over long service life. Elastomeric (rubber) insulation / lining should be present such that none of the Stainless Steel Strap is in direct

contact with the pipe. It shall ensure a firm non slip grip mounting on the pipe to prevent the saddle from rocking or creeping on the pipe, as might be caused by vibration, pressure or excessive external loading.

Fasteners: Fasteners shall be threaded type. Fasteners shall be Stainless Steel Type SS 304 and NC rolled thread design. Fasteners of size 12mm (M12) shall be used for saddles of size up to 100mm (NB 100) and Fasteners of size 16mm (5/8") (M16) shall be used for saddles of size 150mm (NB 150) and above. The SS nut shall be welded to the strap for easy fixation of bolts.

- (ii) **DI Strap Saddle:** DI Strap Saddle for service connection on Ductile Iron water distribution mains shall be of wrap around design and wide skirt for proper support which provides excellent stability to the saddle and reinforce the pipe. Manufacturers must have ISO 9001 for at least past five years. Manufacturer specification, Quality assurance plan (QAP) to be submitted by the respective bidder for the client/consultant approval. It shall be compatible for assembly on DI distribution mains pipe manufactured in accordance with ISO 2531/ EN545 / EN598 standard. Saddle fittings shall be suitable for maximum working pressure 16 bar (kg/cm²) with outlet/ branch sizes in 12mm, 20mm, 25mm, 32mm, 40mm and 50mm. It should be compatible with the dry tapping tools to create leakage free tapping on dry Ductile Iron water distribution pipes while installed on the pipe.

Material of Construction:

- a) Body: Ductile Iron cast body.
- b) Body Coating: Epoxy coating approved for drinking water of minimum 250 micron.
- c) Seal: EPDM rubber joint suitable for drinking water.
- d) Saddle wrap/strap shall be Stainless Steel to prevent corrosion over long service life. Elastomeric (rubber) insulation / lining should be present such that none of the Stainless Steel Strap is in direct contact with the pipe
- e) Blue/Black EPDM/NBR rubber insulating profile.
- f) Fasteners shall be threaded type. Fasteners shall be SS 304 and NC rolled thread design. The SS nut shall be welded to the strap for easy fixation of bolts.

3. Dry Type Drilling & Tapping Machines for DI Pipes:

The Drilling/tapping machine should be fit for the saddles (Dry Pressure). It should be capable for drilling on Cast Iron, Ductile Iron, steel pipes of various diameters {100mm (NB 100), 150mm (NB 150), 200mm (NB 200)} into the water mains through saddles. It should be hand operated (ratchet handle), easy maintained and highly durable to ensure simple installation of ferrule to the main pipe. All kit components shall be manufactured in top materials, with excellent surface finishes and are designed to withstand hard work with only minimum maintenance. The tapping tool kit shall be designed to fit on the metallic insert of the composite strap saddle perfectly in order to drill the pipe with the saddle already fitted.

The tool shall be designed without complicated aperture such as chains and belts to hold the pipe. The tapping/drilling tool shall be designed in such a way to minimize torque requirements while making the hole on pipes. It should be tempered with nickel-plated steel drilling device, with tempered ground stainless steel shaft.

Each machine kit should comprise of the required size and number of drill bits

4. Electro Fusion Tapping Tee with inbuilt cutter (PE 80/100 Black):

House service connections from the HDPE Pipeline shall be taken by providing, Wrap around type Electro Fusion tapping Saddle / tapping tee, which shall be compatible for fusing on either PE 80 or PE 100 distribution mains pipe manufactured in accordance with IS 4985. The body should be Virgin compounded PE 100 Black polymer and Composite cutter should be Brass & Polymer. EF PE / PP Yarn belt Wrap Around tapping saddle Fittings manufacturers must have ISO 9001, ISO 14000 and ISO 18001 certification for their QMS, EMS & OHSS systems.

Pressure rating will be SDR 11 (PN 16). The grade of PE raw material used must be certified by an Indian or International certifying body from their certified laboratories and certificate of Compliance to be produced for the following parameters:

- i) Odour & flavour of water
- ii) Appearance of water
- iii) Growth of micro organism
- iv) Extraction of substances that may be of concern to public health

EF Tapping Saddle / Tapping Tee should be with only a single heating coil to fully electro-fuse the fitting to the adjoining pipe or pipe component as applicable. The heating coils shall be terminated at terminal pins of 4.0 or 4.7 millimeter diameter. No heating element shall be exposed and all coils are to be integral part of the body of the fitting. The bidder is required to submit copy of certificates from WRAS (Water Regulations Advisory Scheme)/ KIWA/CIPET for their products for drinking water applications. The heating elements should be designed for fusion at any ambient temperatures between -5°C to +45°C with auto temperature compensation using automatic barcode reader fusion machine i.e. without need for any manual compensation of fusion time for different ambient temperatures.

5. Electro fusion Welding Machine:

The electro fusion control unit shall be designed for use with electro fusion fittings of 40V. The unit shall operate in two modes, Automatic & Manual. The unit shall be complete with all accessories and shall have the following features as minimum.

- a) All units are to be provided with a single push button start and have additional information recoverable.
- b) The initial power supply to enable the control unit to function correctly for all fitting and saddle sizes up to nominal diameter 630 mm should not exceed 4 KWA.
- c) The unit is to be designed with an automatic compensator so that it can fully operate within input tolerances of between 180 and 264 Volt, respectively 45 and 65 Hz.
- d) The units are to operate with a stabilized fusion voltage.
- e) The range of fusion voltage is to be between 39 and 40 volts.
- f) The display shall be scratch-resistant, back-lit, be easily readable, have an adjustable contrast function and give relevant information such as:
 - recognition of fitting type, dimension and manufacturer
 - resistance of connected fitting
 - a check-system prior to commencement of fusion process
 - actual running and final fusion time in seconds
 - primary voltage and frequency
 - ambient temperature.
 - individual fusion number and unit number
 - mode of data transfer
 - appropriate cooling time
- g) A temperature sensor is to be provided.
- h) The minimum operating range of ambient temperatures is to be between -10° and +45°C and the unit must be equipped with an external ventilator for continual operation.
- i) The unit must be capable of recognizing and processing different manufacturer's products.

- j) Adapter clips for 4 mm terminal pins are to be available.
- k) An external memory bank must be able to record at least 350 fusion records and be easily accessible and exchangeable.
- l) The complete control unit must be contained in one single housing and not exceed a maximum weight of 21 kilograms including all standard primary and secondary cables.
- m) The supplier must be able to provide a full range of system software and data transmission accessories as applicable for data processing.
- n) Ability to download fusion records from all memory systems via an RS 232 interface is to be provided.
- o) A back-up internal reserve memory with override must to be provided.
- p) The protection class of the unit shall be at least IP 54.
- q) A lightweight transport box with internal document pocket is to be provided.
- r) All control units must fulfill the Electro-Magnetic Compatibility regulations in accordance with the latest European standards.
- s) The related pipe jointing accessories such as Pipe cleaners, Manual peeler/scrapper are to be supplied by the same electro fusion fitting/machine supplier to ensure perfect jointing.

Data Sheet

Operating Temperature Range (Min).	-10 to +45 Deg. C
Operating Voltage Range (min)	190 V to 265 V, 40 to 70 Hz
Output Voltage	39 to 40 V
Enclosure Protection	IP 54 class1
Input Cable length	Minimum 3 meters
Output Cable length	Minimum 3 meters

6. MDPE Pipes and Fittings:

MDPE PE 80 Blue Pipes shall conform to ISO 4427 for conveyance of Potable water for Human Consumption and to be tested to comply with BS 6920 specifications in any of the laboratories like WRC/ \CIPET (India)/DVGM/KIWA/SPGN and certificate of compliance to be produced for the following parameters:

- Odour & Flavour of Water
- Appearance of Water
- Growth of Micro Organism
- Extraction of substances that may be of concern to Public Health (Cyto Toxicity)
- Extraction of Metals.

The Pipes shall be manufactured from virgin natural resin PE 80 food grade compounded raw material, containing those anti – oxidants, UV Stabilizers & Pigments necessary for manufacturing of pipes. Reworked material, generated from manufacturer's own production of pipes, shall not be used. The Pipes shall be designed for the nominal working pressure class PN 16 and shall have minimum required strength of material as 8Mpa at 20° C, as per ISO 4427: 1996.

Pressure Rating: The Pressure rating of MDPE Blue PE 80 Pipes shall be confirming to ISO 4427: 1996.

Colour of Pipes: The Colour of MDPE PE 80 Pipes shall be BLUE confirming to ISO 4427: 1996.

Dimensions: The pipe dimensions shall be as per latest revisions of ISO 4427 and pipes upto diameters 32 mm shall be supplied in Coils of 100- 300 m. The internal diameter, wall thickness, length and other

dimensions of pipes shall be as per relevant tables of ISO 4427:1996. Each pipe shall be of uniform thickness throughout its length.

The dimension tolerances shall be as per ISO 4427

Performance requirements: The Pipe supplied should have passed the acceptance test as per ISO 4427. The manufacturer should provide the test certificates for the following tests.

- Melt Flow Rate
- Density,
- Oxidation and Induction test,
- Hydrostatic Test ,
- Pigment dispersion Test,
- Longitudinal Reversion Test.

Compression fittings PN 16 rated shall be conforming to ISO 14236 and its latest versions and shall be tested as per ISO:3459, ISO 3501 & ISO:3503, in food grade poly propylene and suitable for drinking water supply, which shall be certified by WRAS, UK/KIWA, etc.,

- ISO 3458: Assembled joints between fittings and polyethylene pipes: test of leak-proof ness under internal pressure.
- ISO 3459: Polyethylene pressure pipes joints assembled with mechanical fittings: test of internal pressure.
- ISO 3501: Assembled joints between fittings and polyethylene pressure pipes: test of resistance to pull out.
- ISO 3503: Assembled joints between fittings and polyethylene pressure pipes: test of leak-proof under internal pressure when subjected to bending.

If the pipes and fittings are not produced by the same manufacturer, the Contractor shall perform the above tests at his own expense at an approved laboratory.

7. Supply of Ball valve /Stop cock:

Each service connection will be provided with a Compression End UPVC Ball Valve (or any other material conforming BS 6920) PN 16 rating, with one end compression and the other end with female thread conforming to ISO:4422-4 and ISO:7/BS:21/IS:554, etc., which will be installed before the consumer meter. The raw materials should have undergone type tests as specified in BS 6920.

8. Cast Iron Y-Strainer:

Test Pressure: (Hydraulic): 21.1kg/cm². Specification:

Parts Name	Material	Specifications
Body & Cover	Cast Iron	IS 210 FG 200
Strainer	Stainless Steel	IS 7604
Gasket	Steam Jointing Sheet	IS 2712 Gr.W/3
Bolts & Nuts	Carbon Steel	IS 1363

These Y type strainer should have the capacity to alienate the solids from the liquid and does not require everyday clean outs. Offered strainers should be broadly use in pipelines to protect meters, pumps, regulators, steam traps and other related equipment.

Application

- Water
- Steam
- Oil

Technical Specifications:

- Design: 'Y' Type
- Body Material: Cast Iron, Carbon Steel (ASTM A 216 GR. WCB, Forged Carbon Steel (ASTM A 105), CF8 (SS 304), CF8M (SS 316), CF3M (SS 316L), SS 202, Alloy Steel & Others.
- End Connection: Screwed (Threaded), Socket Weld, Flanged End.
- Pressure Rating Class: ASA 150, 300, 600.
- Size Range: 12mm to 400mm

9. Pressure-Reducing Valves

Most of the plumbing codes require water pressure reducing valves on domestic systems where the water main's pressure exceeds 55 m head to avoid high pressures causing rupture of pipes & fittings and injure the people using them. Water entering the valve from mains is constricted within the valve body and directed through the inner chamber controlled by an adjustable spring loaded piston/diaphragm and disc. Even if the supply water pressure fluctuates, the pressure reducing valve ensures a constant flow of water at a functional pressure, as long as the supply pressure does not drop below the valve's pre-set pressure.

The Pressure Reducing Valve should be as per BS EN 1567:2000 or any equivalent standards applicable for drinking water supply.

Pressure-reducing valves (PRVs) shall be of the pressure compensated piston or diaphragm controlled, designed to reduce a variable inlet pressure to a pre-determined constant outlet pressure at varying flows. Valves shall be drop tight under no flow conditions.

The body of the PRV shall be made with bronze or brass or any equivalent material with integral strainer of stainless steel 316. All necessary repairs to the valve should be possible without removing the valve from the service connection pipe.

The pressure setting shall be capable of being adjusted on site by the use of an adjustment screw to alter the compression of the spring. The opening and closing speeds shall also be field adjustable by adjusting the flow regulation screw. The valves shall be capable of being fully opened or fully closed by respective opening and closing of upstream and downstream ground cocks.

These pressure reducing valves shall regulate downstream pressures to set values. Nominal pressures will be Inlet Pressure (0.25-1.6 MPa)/ Outlet Pressure (0.1-0.6 MPa) rating. Body ends shall be equipped with suitable and standard threads or connection arrangement which is capable of developing leak proof joint.

10. Supply of GI pipes (Medium)

GI pipes conforming to IS 1239 of sizes 50mm and 80mm should be provided for casing along with pipe specials and fittings (Heavy).

11. Supply of HDPE Pipes and Fittings

Supplying HDPE pipes PE 100, PN 16 shall conform to IS 4984:1995 with latest amendments.

Raw material used to manufacture the HDPE pipes shall be virgin compounded or Natural black PE 100 resin conforming to ISO 4427:2007. The carbon black content in the material shall be within $2.5 \pm 0.5\%$ and the dispersion of carbon black shall be satisfactory when tested as per ISO 2530.

The PE100 black compound proposed to be used for manufacturing of the pipes should also comply with the following norms certified by the raw material manufacturer from an independent third party laboratory like Exova (formerly Bodycote), KIWA, CIPET, etc. which should be submitted by the pipe supplier.

The raw material should have certification as per ISO 9080:2003 and ISO 12162 by an independent international testing laboratory for having passed 10,000 hour long term hydrostatic strength (LTHS) test extrapolated to 50 years to show that the resin has a minimum MRS of over 10 MPa. Certification

as per ISO 13477:2008- Determination of resistance to rapid crack propagation (RCP) - small – scale steady state test (S4 test). Internal certificate of any resin manufacturer shall not be acceptable.

Certificate for having passed the full scale rapid crack propagation test as per ISO 13478. Tolerance & ovality, Wall thickness as per allowable hydrostatic design stress, minimum & maximum wall thickness and Testing of Pipes will be as specified in IS 4984.

All HDPE fittings/specials shall be fabricated or injection moulded at factory as per IS: 8360(Part-I & Part-III) and as per IS: 8008 (Part-I to Part-IX). Fittings will be butt welded on the pipes or other fittings by use of heat fusion.

12. Installation of Water Meter and Valves

The meter shall be fixed in a position by means of connecting pipes, jam nut and socket etc. The paper disc inserted in the ripples of the meter shall be removed and the meter shall be installed exactly horizontally in the flow line in the direction shown by the arrow cast on the body of the meter. Care shall be taken to not to disturb the factory seal of the meter. Wherever the meter shall be fixed to a newly fitted pipeline, the pipeline shall have to be completely washed before fitting the meter.

13. Water Meter Box

General Requirement: Meter Box is to be provided to encompass & protect water meters installed on drinking water supply pipes. It should be of two components, comprising body and lid. Provision for embossed marking on the lid and body as per client requirement.

Raw Material: The material of construction of the lid and body of the valve box is weather resistant PE/PP/Thermosetting Plastic.

Minimum Dimensions: Length 355 mm x breadth 270 mm x height 180 mm

Lid fixing: Press fitted type only. No hinges should be used for open /close operation.

Locking: With built in lock.

Cut-outs for passing pipes: The body must have inlet and outlet windows to pass the pipe through. It should be suitable for use with pipes of sizes up to 2” (50 mm) with suitable sealing of the cut-outs of pipe inlet and outlet with material having same durability as the meter box.

Performance Requirement: In its properly installed position, must be able to take load of human traffic and small vehicular load that usually appear in residential areas.

It must pass test of load bearing when applied dead load of 100 kg on the meter box top for 1 hour, without any side support. No signs of deformation of the box shall be are observed.

Installation: Meter Box shall be installed to the floor using anchor bolts/screws without grouting the entire base of the meter box, if necessary by raising the base to avoid waterlogging.

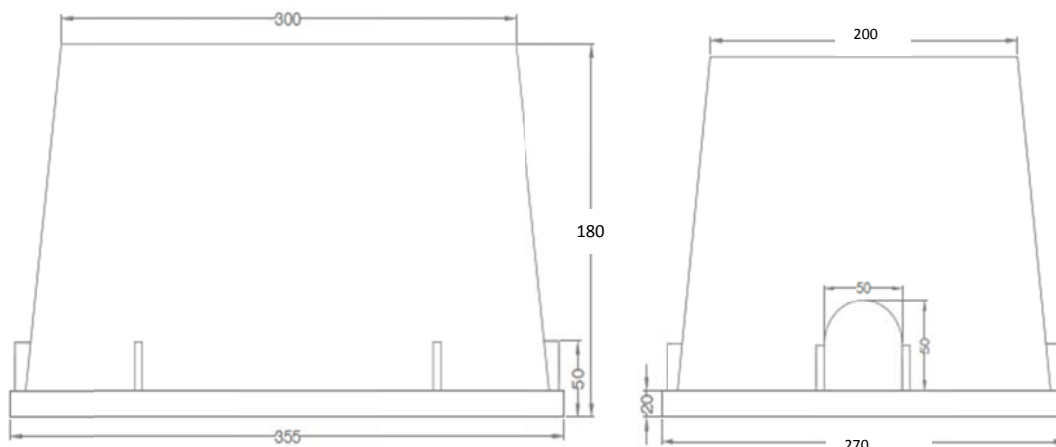

14. Excavation Work:

Soil:

This classification shall comprise all kinds of soil, turf, sand, silt, loam, clay, mud, peat, black cotton soil, soft shale or loose murrum, a mixture of these and similar materials. All soils covered in ordinary and hard soils shall be covered in this category. Removal of gravel or any other nodular material having dimension in any one direction not exceeding 75 mm occurring in such strata shall be deemed to be covered under this category.

Ordinary Rock (not requiring blasting):

This classification shall include rock types such as laterites, shales and conglomerates, varieties of limestone and sandstone etc., which may be quarried or split with crow bars or pneumatic rams. This classification also includes any rock which in the dry state may be hard and requires blasting, but which when wet becomes soft and can be excavated by a means other than blasting.

Macadam surfaces such as water bound and bitumen bound road surfaces, paths etc. and hard core compact murrum or stabilized soil requiring a grafting tool or pick to excavate them will be considered in this category. Gravel and cobble stone having a maximum dimension in any one direction between 75 and 300 mm shall also be included.

Lime concrete, stone masonry in lime mortar and brick work in lime/cement mortar below ground level, reinforced cement concrete which may be broken up with crow bars or picks and stone masonry in cement mortar below ground level shall be included in this category.

Boulders which do not require blasting having a maximum dimension in any direction of more than 300 mm, found lying loose on the surface or embedded and terrace material of dissimilar origin shall be included in this category.

Hard Rock (Requiring Blasting):

Hard Rock by General Blasting: Any rock or cement concrete for which the use of mechanical plant and/or blasting is required; reinforced cement concrete (reinforcement cut through but not separated from the concrete) below ground level; and large boulders requiring blasting.

Hard Rock by Controlled Blasting: In a case where hard rock is to be excavated by blasting, but requires special precautions to prevent damage to nearby property by flying rock pieces and due to vibrations caused by blasts, the blasting will be carried out in controlled manner. The control measures shall include setting a reduced charge for blasting, covering the blast holes by steel sheets covered with sand bags, establishing traffic control, etc.. This shall be carried out as per specific approval of the Employers Representative.

Hard Rock (Blasting Prohibited)

Hard rock requiring blasting as described above but where blasting is prohibited for any reason and excavation has to be carried out by chiseling, wedging or any other agreed upon method.

Care for Public Utilities

During commencement of the work the contractor should communicate with all the local authorities and request for the plan of their facilities although it does not need to be very exhaustive. It is the contractor's responsibility to protect the existing utility from any damage caused by or occurring during their operations and repair of damaged utilities shall be at the expense of contractor.

Limits of Excavation and Restoration

The contractor shall disturb only that portion of the street and public or private property necessary for execution of the work and abide by the all prevailing rules of working on the streets. The work should cause a minimum of inconvenience to persons residing or moving near the work location. The Contractor shall protect all excavations by barricades, lights and other warning devices. When service

connections are installed prior to rough grading, a minimum of 0.5 m deep earth filling shall be placed over the pipes and fittings.

Upon completion of the service connections, the public and private property shall be restored amicably as per the earlier condition.

The maximum length of open trench will be the distance necessary to accommodate the amount of pipe installed in a single day. To the extent practical, trenches shall be fully backfilled each day. At any time a trench is unattended, the entire trench shall be protected with a minimum of 1.5 m high barricading.

Dewatering of Pipe trenches

The contractor shall provide and operate suitable dewatering equipment to maintain trenches with no accumulation of water (from ground or pipes) and the water table is maintained at least 300 mm below the bottom of the trench during excavation, pipe laying and backfilling. Special care shall be exercised to prevent excessive and rapid drawdown of water table and rate of pumping shall be maintained in such a manner that no adverse structural effects on buildings and other structures are caused and no instability of the ground should be caused. Dewatering of trenches shall not cause any obstruction the functioning of normal storm drainage system with drainage water containing solid particles, floating matter, debris, etc. The contractor shall clear and maintain surface and underground drains of all such matter to prevent inconvenience to public and avoid damages to property.

15. Trench Backfilling and Compaction

All trenches shall be backfilled as soon as practicable. When suitable material is not available from excavations the contractor may opt for select material for backfilling or for blending with existing material. The quantity and quality of the selected material shall be subject to the approval of the Engineer.

Placing and compacting of trench backfill including blending of backfilling materials, adding moisture or drying of materials, and procuring suitable materials from excavations within the project shall be considered as incidental to trench excavation or to the items for pipe.

Backfill material placed within 0.5 m of subgrade shall be compacted to a density of not less than 100 percent of maximum density and the relative moisture content shall be not more than 102 percent of optimum moisture content. Subgrade shall be defined for this section as the elevation of the bottom of any aggregate material placed for pavement or sidewalk or the bottom of the topsoil for turf establishment.

16. Road Restoration

The contractor shall be responsible to ensure that all existing asphalt roads, brick road, concrete roads, paver block roads and WBM roads are reinstated as stated in typical drawings, immediately after hydraulic testing of the pipeline and backfilling has been completed. The finished levels of the completed reinstatement shall conform to the adjoining carriageway surface. Reinstated road shall match as nearly as practicable to the characteristics of the existing road.

Water Bound Macadam Road

This work shall consist of providing clean and crushed aggregates, laying & compacting of WBM sub-base / base course by rolling and bonding together with screening, binding material where necessary and watering, including preparation and compaction of sub-base & spreading of crushed aggregate to proper grade and camber including application of screenings for interlocking, sprinkling of water & rolling with power roller as per instructions of the Employers Representative, shall be as specified below.

- a. Grading No.1 material 90 to 45 mm size with stone screenings & binding material, 200 mm thick.
- b. Grading No.2 material 63 to 45 mm size with stone screenings & binding material, 100 mm thick.
- c. Grading No.3 material 53 to 22.4 mm size with stone screenings & binding material, 80 mm thick.

Bituminous Macadam

Coarse Aggregate 53 mm to 2.8mm size with bitumen spray grout at 15kg /10.Sq.m, 50mm thick.

Bituminous Concrete

Course Aggregate 22.4 to 2.8mm size bitumen spray at 15 kg / 10 sq.m, 25mm thick.

Pre-mix

Premix seal coat with pre-mix aggregate size passing through 2.36mm sieve at 0.6 kg/10sq.m. mixed with binder at 6.8 kg / 10sq.m.

Prime Coat – Providing and applying a primer coat at 0.6kg/m² with bitumen emulsion CSS-1 (IS 8887 – 2004) on prepared surface of WBM including cleaning of road surface and spraying primer at the rate specified using mechanical means.

Tack coat (TC) - Providing and applying tack coat with bitumen emulsion, using emulsion pressure distributor, at 0.2 kg/m² on the prepared surface, after cleaning broom. The bitumen emulsion shall be of CSS-1h for a normal bituminous surface. The materials shall be tested at the site and in a laboratory.

Cement Concrete Road

The concrete road shall be of M20 plain concrete of 200 mm thick. This work, if applicable anywhere as per direction of Employers Representative, shall conform to Standard specification – Cement concrete pavement under Road Section.

17. Testing

The Contractor is required to test individual house connection pipeline including water meter and other accessories for hydrostatic pressure test between ferrule point and including water meter using clean water with the approval of the Engineer. In case of header pipes laid for giving house connections from distribution main, hydrostatic pressure test may be conducted including the header pipe and house connections pipelines together at a time.

The pressure in the test section is allowed to stabilize for approximately 3 hours. No make-up water/pressure shall be applied to the test section during this 3 hours stabilization period. Thermoplastic pipes expand under pressure due to low modulus of elasticity and this result in initial fall of pressure. Without any additional requirement of makeup water, the test pressure should not fall more than 0.20 kg/sq.cm at the end of one hour test duration.

All pressure testing at site should be carried out hydraulically. The pipes shall be accepted to have passed the pressure test satisfactorily, if the quantity of water required to restore the test pressure does not exceed the amount 'Q' as calculated below in the formula and the pressure drop limitations specified in case of HDPE pipelines. No pipe installation shall be accepted until the leakage is less than the amount 'Q' as determined below;

$Q = 1 \text{ l per km per } 10\text{mm of pipe diameter per each } 30 \text{ m of test pressure per } 24 \text{ hours}$



Gauges used for pressure testing pipelines shall have a dial diameter of not less than 100mm and a full scale reading not greater than twice the specified test pressure. Before any gauge is used the Contractor shall arrange for it to be checked independently and a dated certificate of its accuracy shall be provided to the Employer's representative. The Employer's representative shall be permitted to order his own independent test of the Contractor's gauges.

The pipeline stretches shall be tested to the pressure equal to 1.5 times the maximum operating pressure in the pipeline stretch under test, subject to maximum of 16 kg/sq.cm. Operating pressure shall be equal to static pressure on the pipeline invert level with respect to zonal supply reservoir full tank level.

The Contractor shall at his own expenses provide all water required for filling, testing and retesting pipelines, and any pumps, electricity, auxiliary piping, fittings, pressure gauges and personnel required for the testing program.

All leaks and defects in joints revealed during the testing shall be rectified and got approved at site by retest.

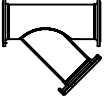
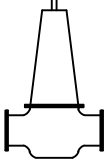
S. NO	Description
1	DI Main
2	D.I Saddle with BSP outlet
3	Ferrule
4	MDPE Metal Threaded Adaptor
5	MDPE Pipe
6	MDPE elbow
7	MDPE Ball valve

S.I NO	Legend	
A	Strainer	
B	P.R.V	
C	Meter	

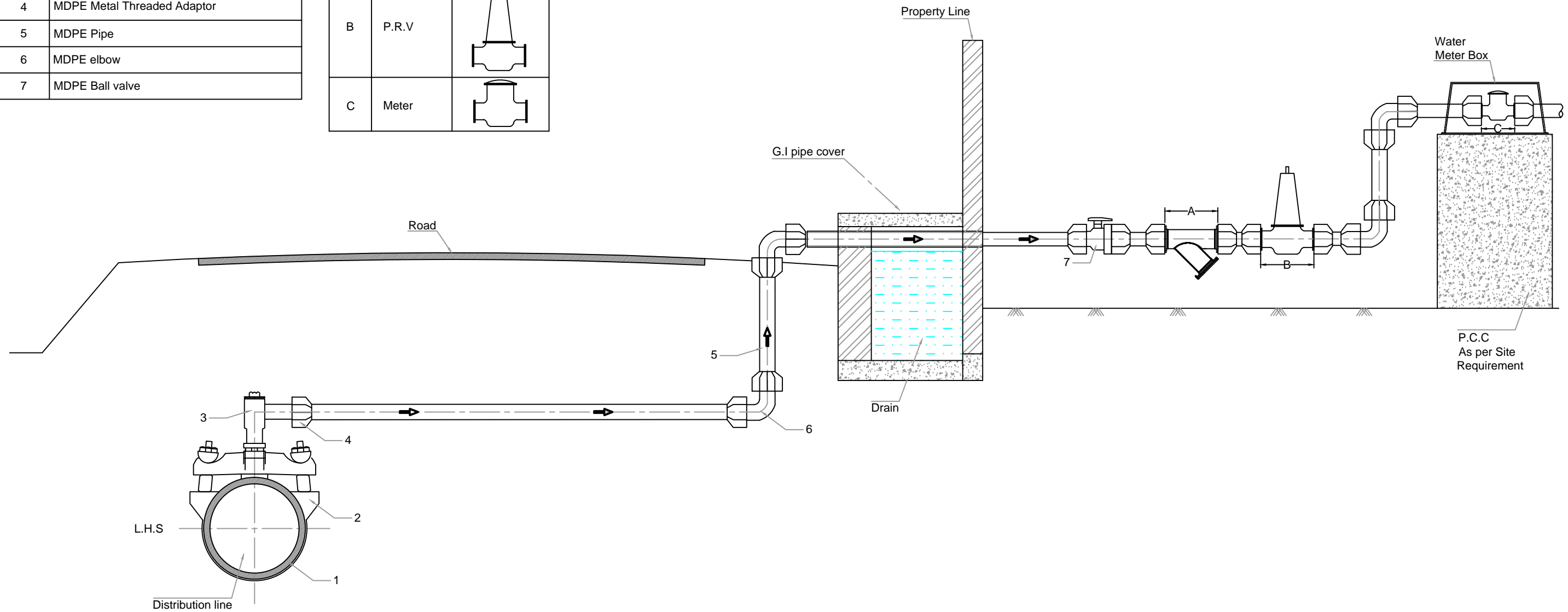

Size of the connection in plastic pipe (MDPE)	Bore dia in Distribution pipe	Size of Meter
20 mm	16 mm	16 mm
25 mm	20 mm	20 mm
32 mm	25 mm	25 mm
40 mm	32 mm	32 mm
50 mm	40 mm	40 mm
63 mm	51 mm	51 mm

Distribution pipe dia	Size of connection in mm (OD)
100 mm	20,25
150 mm	20, 25, 32, 40
200 mm	25, 32, 40, 50, 65
250-300 mm	32, 40, 50, 65, 100

Description	Stop Valve	Strainer	PRV	Meter
High Pressure Zone static head more than 55 m	✓	✓	✓	✓
Average pressure zone less than 55 m head but more than 12 m	✓	✓	✗	✓
Low pressure zone i.e head is less than 12 m	✓	✗	✗	✓

Consultants:
PROJECT MANAGEMENT CONSULTANT (PMC)
 NJS Consultants Co., Limited
 Saikia Commercial Complex,
 3rd Floor,
 Christian Basti,
 G.S.Road
 Guwahati - 781005

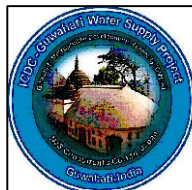

Project:
PROJECT MANAGEMENT CONSULTANTS (ICDC)
HSC FOR SOUTH WEST GUWAHATI & SOUTH CENTRAL GUWAHATI AREA

Client:
PROJECT DIRECTOR, PIU
 Saikia Commercial Complex, 2nd Floor, Christian Basti,
 GS Road, Guwahati – 781005, Assam, India.

3		
2		
1		
0	04.09.2018	For Tendering Purpose
REV NO.	DATE	REMARKS

Approved by: R.Radhakrishnan
 Checked by: BMS Murthy
 Drawn by: Dhanjit Deka
 Design by: K.Sathish Kumar
 Scale: N.T.S

Title:
Typical Drawing for House Service connection on D.I pipe. Type I Long Side (Property Below Road Level)

Drg. no:
 GWSP/HSC/01

S. NO	Description
1	DI Main
2	D.I Saddle with BSP outlet
3	Ferrule
4	MDPE Metal Threaded Adaptor
5	MDPE Pipe
6	MDPE elbow
7	MDPE Ball valve

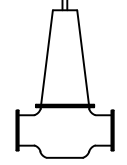
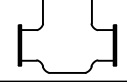
S.I NO	Legend	
A	Strainer	
B	P.R.V	
C	Meter	

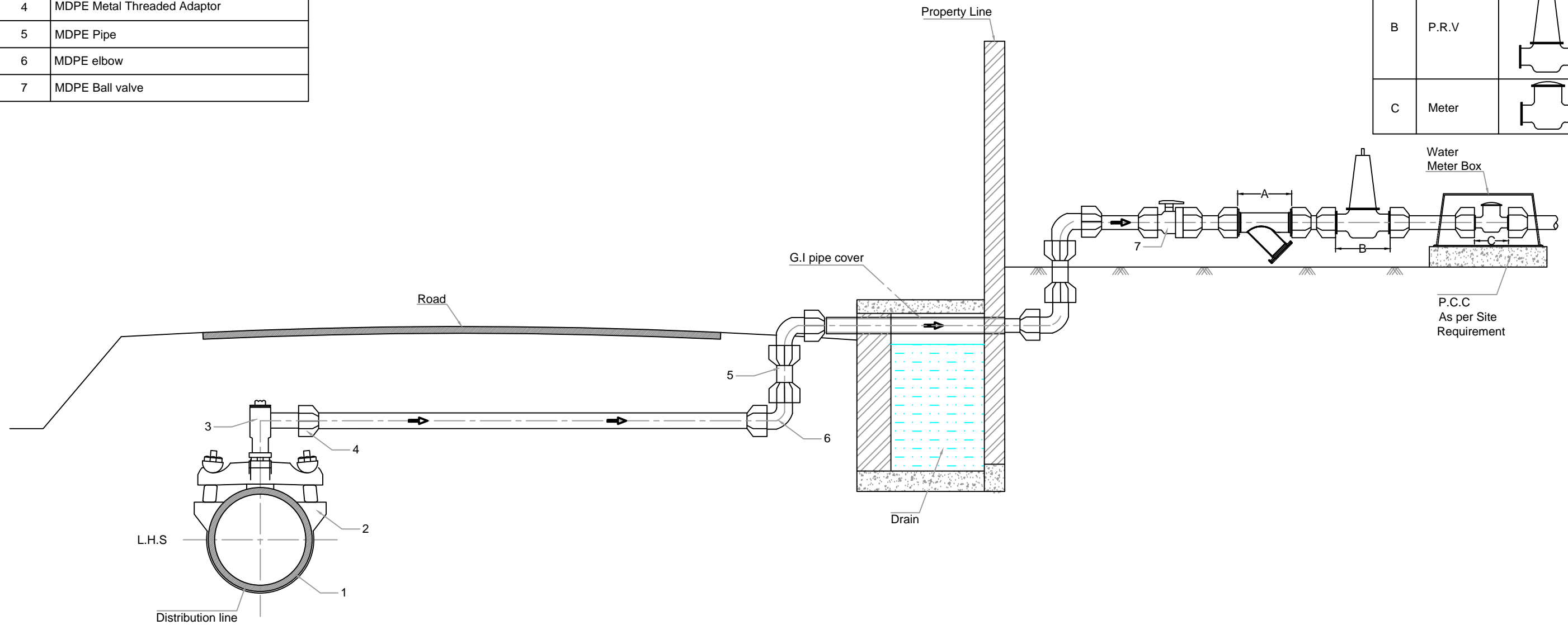

Size of the connection in plastic pipe (MDPE)	Bore dia in Distribution pipe	Size of Meter
20 mm	16 mm	16 mm
25 mm	20 mm	20 mm
32 mm	25 mm	25 mm
40 mm	32 mm	32 mm
50 mm	40 mm	40 mm
63 mm	51 mm	51 mm

Distribution pipe dia	Size of connection in mm (OD)
100 mm	20,25
150 mm	20, 25, 32, 40
200 mm	25, 32, 40, 50, 65
250-300 mm	32, 40, 50, 65, 100

Description	Stop Valve	Strainer	PRV	Meter
High Pressure Zone static head more than 55 m	✓	✓	✓	✓
Average pressure zone less than 55 m head but more than 12 m	✓	✓	✗	✓
Low pressure zone i.e head is less than 12 m	✓	✗	✗	✓

Consultants:
PROJECT MANAGEMENT CONSULTANT (PMC)
 NJS Consultants Co., Limited
 Saikia Commercial Complex,
 3rd Floor,
 Christian Basti,
 G.S.Road
 Guwahati - 781005

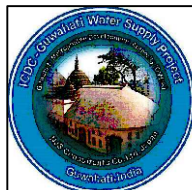

Project:
PROJECT MANAGEMENT CONSULTANTS (ICDC)
HSC FOR SOUTH WEST GUWAHATI & SOUTH CENTRAL GUWAHATI AREA

Client:
PROJECT DIRECTOR, PIU
 Saikia Commercial Complex, 2nd Floor, Christian Basti,
 GS Road, Guwahati – 781005, Assam, India.



3		
2		
1		
0	04.09.2018	For Tendering Purpose
REV NO.	DATE	REMARKS

Approved by: R.Radhakrishnan
 Checked by: BMS Murthy
 Drawn by: Dhanjit Deka
 Design by: K.Sathish Kumar
 Scale: N.T.S

Title:
Typical Drawing for House Service connection on D.I pipe. Type II Long Side (Owner Property Above Road Level)

Drg. no:
 GWSP/HSC/02

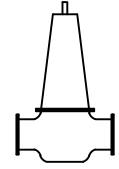
S. NO	Description
1	DI Main
2	D.I Saddle with BSP outlet
3	Ferrule
4	MDPE Metal Threaded Adaptor
5	MDPE Pipe
6	MDPE elbow
7	MDPE Ball valve

S.I NO	Legend	
A	Strainer	
B	P.R.V	
C	Meter	

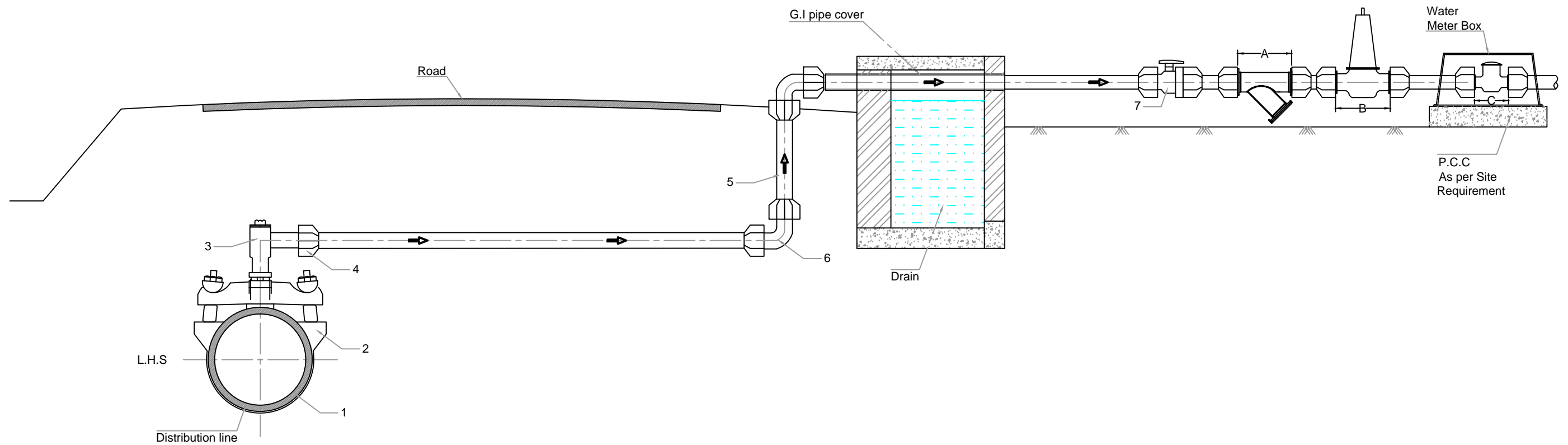

Size of the connection in plastic pipe (MDPE)	Bore dia in Distribution pipe	Size of Meter
20 mm	16 mm	16 mm
25 mm	20 mm	20 mm
32 mm	25 mm	25 mm
40 mm	32 mm	32 mm
50 mm	40 mm	40 mm
63 mm	51 mm	51 mm

Distribution pipe dia	Size of connection in mm (OD)
100 mm	20,25
150 mm	20, 25, 32, 40
200 mm	25, 32, 40, 50, 65
250-300 mm	32, 40, 50, 65, 100

Description	Stop Valve	Strainer	PRV	Meter
High Pressure Zone static head more than 55 m	✓	✓	✓	✓
Average pressure zone less than 55 m head but more than 12 m	✓	✓	✗	✓
Low pressure zone i.e head is less than 12 m	✓	✗	✗	✓

Consultants:
PROJECT MANAGEMENT CONSULTANT (PMC)
 NJS Consultants Co., Limited
 Saikia Commercial Complex,
 3rd Floor,
 Christian Basti,
 G.S.Road
 Guwahati - 781005

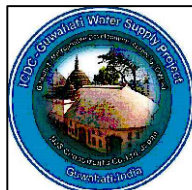

Project:
PROJECT MANAGEMENT CONSULTANTS (ICDC)
HSC FOR SOUTH WEST GUWAHATI & SOUTH CENTRAL GUWAHATI AREA

Client:
PROJECT DIRECTOR, PIU
 Saikia Commercial Complex, 2nd Floor, Christian Basti,
 GS Road, Guwahati – 781005, Assam, India.

3		
2		
1		
0	04.09.2018	For Tendering Purpose
REV NO.	DATE	REMARKS

Approved by: R.Radhakrishnan
 Checked by: BMS Murthy
 Drawn by: Dhanjit Deka
 Design by: K.Sathish Kumar
 Scale: N.T.S

Title:
Typical Drawing for House Service connection on D.I pipe. Type III Long Side (Without Owner Property Boundary)

Drg. no:
 GWSP/HSC/03

S. NO	Description
1	DI Main
2	D.I Saddle with BSP outlet
3	Ferrule
4	MDPE Metal Threaded Adaptor
5	MDPE Pipe
6	MDPE elbow
7	MDPE Ball valve

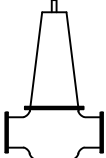
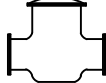
S.I NO	Legend	
A	Strainer	
B	P.R.V	
C	Meter	

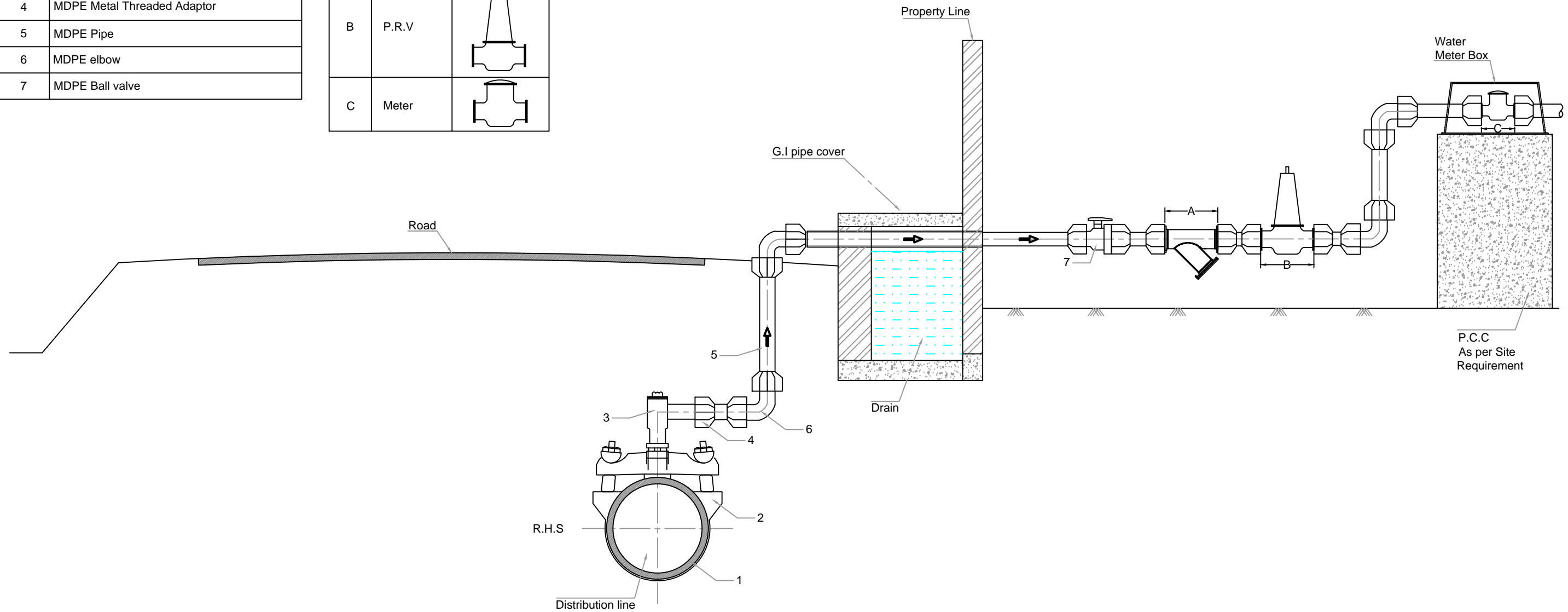

Size of the connection in plastic pipe (MDPE)	Bore dia in Distribution pipe	Size of Meter
20 mm	16 mm	16 mm
25 mm	20 mm	20 mm
32 mm	25 mm	25 mm
40 mm	32 mm	32 mm
50 mm	40 mm	40 mm
63 mm	51 mm	51 mm

Distribution pipe dia	Size of connection in mm (OD)
100 mm	20,25
150 mm	20, 25, 32, 40
200 mm	25, 32, 40, 50, 65
250-300 mm	32, 40, 50, 65, 100

Description	Stop Valve	Strainer	PRV	Meter
High Pressure Zone static head more than 55 m	✓	✓	✓	✓
Average pressure zone less than 55 m head but more than 12 m	✓	✓	✗	✓
Low pressure zone i.e head is less than 12 m	✓	✗	✗	✓

Consultants:
PROJECT MANAGEMENT CONSULTANT (PMC)
 NJS Consultants Co., Limited
 Saikia Commercial Complex,
 3rd Floor,
 Christian Basti,
 G.S.Road
 Guwahati - 781005

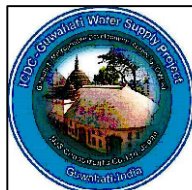

Project:
PROJECT MANAGEMENT CONSULTANTS (ICDC)
HSC FOR SOUTH WEST GUWAHATI & SOUTH CENTRAL GUWAHATI AREA

Client:
PROJECT DIRECTOR, PIU
 Saikia Commercial Complex, 2nd Floor, Christian Basti,
 GS Road, Guwahati – 781005, Assam, India.



3		
2		
1		
0	04.09.2018	For Tendering Purpose
REV NO.	DATE	REMARKS

Approved by: R.Radhakrishnan
 Checked by: BMS Murthy
 Drawn by: Dhanjit Deka
 Design by: K.Sathish Kumar
 Scale: N.T.S

Title:
Typical Drawing for House Service connection on D.I pipe. Type I(a) Short Side(Owner Property Below Road Level)

Drg. no:
 GWSP/HSC/04

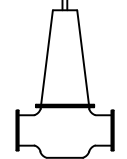
S. NO	Description
1	DI Main
2	D.I Saddle with BSP outlet
3	Ferrule
4	MDPE Metal Threaded Adaptor
5	MDPE Pipe
6	MDPE elbow
7	MDPE Ball valve

S.I NO	Legend	
A	Strainer	
B	P.R.V	
C	Meter	

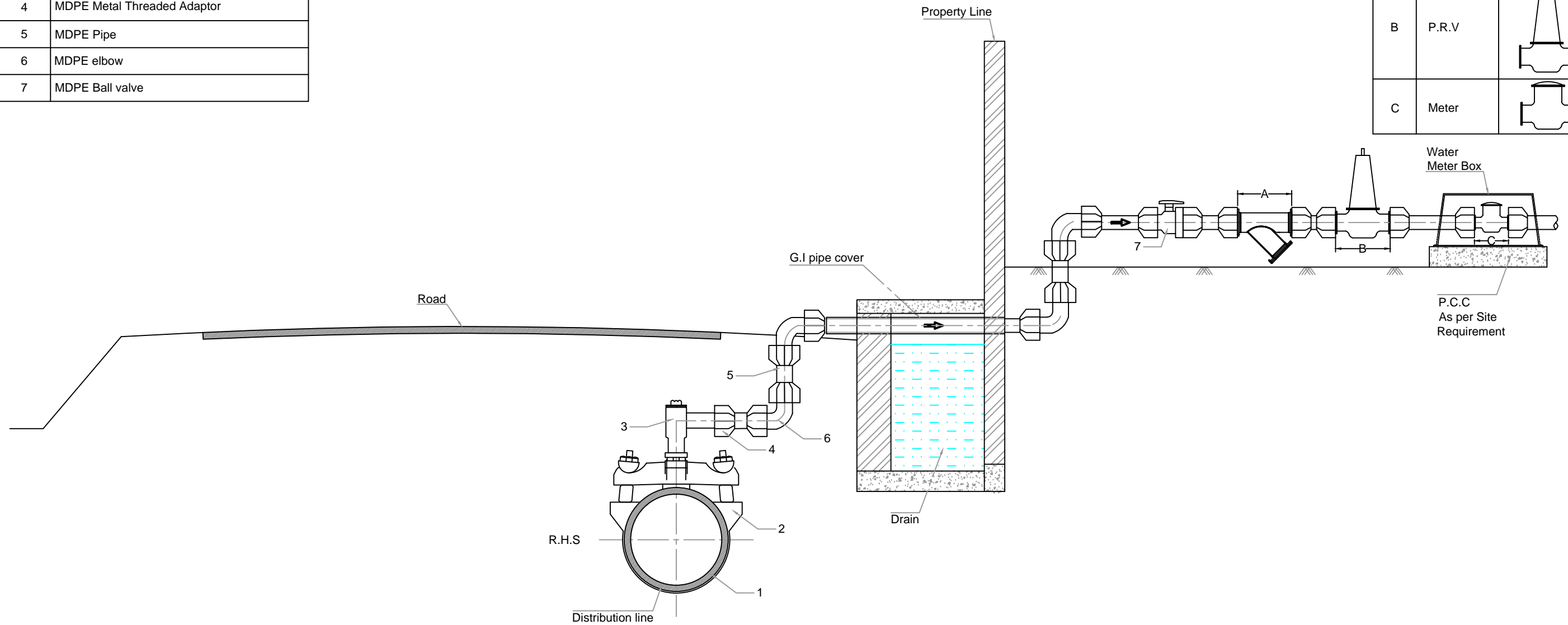

Size of the connection in plastic pipe (MDPE)	Bore dia in Distribution pipe	Size of Meter
20 mm	16 mm	16 mm
25 mm	20 mm	20 mm
32 mm	25 mm	25 mm
40 mm	32 mm	32 mm
50 mm	40 mm	40 mm
63 mm	51 mm	51 mm

Distribution pipe dia	Size of connection in mm (OD)
100 mm	20,25
150 mm	20, 25, 32, 40
200 mm	25, 32, 40, 50, 65
250-300 mm	32, 40, 50, 65, 100

Description	Stop Valve	Strainer	PRV	Meter
High Pressure Zone static head more than 55 m	✓	✓	✓	✓
Average pressure zone less than 55 m head but more than 12 m	✓	✓	✗	✓
Low pressure zone i.e head is less than 12 m	✓	✗	✗	✓

Consultants:
PROJECT MANAGEMENT CONSULTANT (PMC)
 NJS Consultants Co., Limited
 Saikia Commercial Complex,
 3rd Floor,
 Christian Basti,
 G.S.Road
 Guwahati - 781005

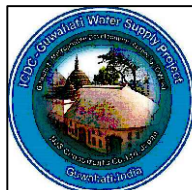

Project:
**PROJECT MANAGEMENT CONSULTANTS (ICDC)
 HSC FOR SOUTH WEST GUWAHATI & SOUTH CENTRAL
 GUWAHATI AREA**

Client:
PROJECT DIRECTOR, PIU
 Saikia Commercial Complex, 2nd Floor, Christian Basti,
 GS Road, Guwahati – 781005, Assam, India.



3		
2		
1		
0	04.09.2018	For Tendering Purpose
REV NO.	DATE	REMARKS

Approved by:	R.Radhakrishnan
Checked by:	BMS Murthy
Drawn by:	Dhanjit Deka
Design by:	K.Sathish Kumar
Scale:	N.T.S

Title:
Typical Drawing for House Service connection on D.I pipe. Type II(a) Short Side (Owner Property Above Road Level)

Drg. no:
 GWSP/HSC/05

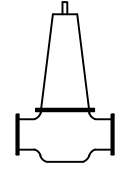
S. NO	Description
1	DI Main
2	D.I Saddle with BSP outlet
3	Ferrule
4	MDPE Metal Threaded Adaptor
5	MDPE Pipe
6	MDPE elbow
7	MDPE Ball valve

S.I NO	Legend	
A	Strainer	
B	P.R.V	
C	Meter	

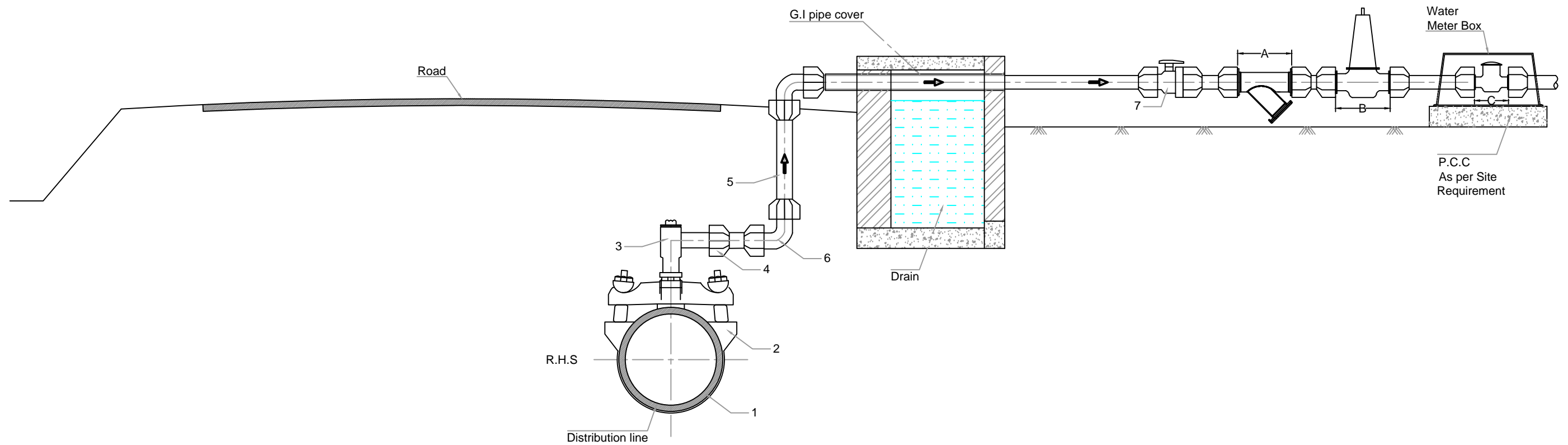

Size of the connection in plastic pipe (MDPE)	Bore dia in Distribution pipe	Size of Meter
20 mm	16 mm	16 mm
25 mm	20 mm	20 mm
32 mm	25 mm	25 mm
40 mm	32 mm	32 mm
50 mm	40 mm	40 mm
63 mm	51 mm	51 mm

Distribution pipe dia	Size of connection in mm (OD)
100 mm	20,25
150 mm	20, 25, 32, 40
200 mm	25, 32, 40, 50, 65
250-300 mm	32, 40, 50, 65, 100

Description	Stop Valve	Strainer	PRV	Meter
High Pressure Zone static head more than 55 m	✓	✓	✓	✓
Average pressure zone less than 55 m head but more than 12 m	✓	✓	✗	✓
Low pressure zone i.e head is less than 12 m	✓	✗	✗	✓

Consultants:
PROJECT MANAGEMENT CONSULTANT (PMC)
 NJS Consultants Co., Limited
 Saikia Commercial Complex,
 3rd Floor,
 Christian Basti,
 G.S.Road
 Guwahati - 781005

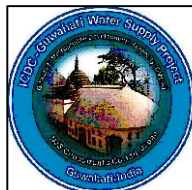

Project:
PROJECT MANAGEMENT CONSULTANTS (ICDC)
HSC FOR SOUTH WEST GUWAHATI & SOUTH CENTRAL GUWAHATI AREA

Client:
PROJECT DIRECTOR, PIU
 Saikia Commercial Complex, 2nd Floor, Christian Basti,
 GS Road, Guwahati – 781005, Assam, India.

3		
2		
1		
0	04.09.2018	For Tendering Purpose
REV NO.	DATE	REMARKS

Approved by: R.Radhakrishnan
 Checked by: BMS Murthy
 Drawn by: Dhanjit Deka
 Design by: K.Sathish Kumar
 Scale: N.T.S

Title:
Typical Drawing for House Service connection on D.I pipe. Type III(a) Short Side(Without Owner Property Boundary)

Drg. no:
 GWSP/HSC/06

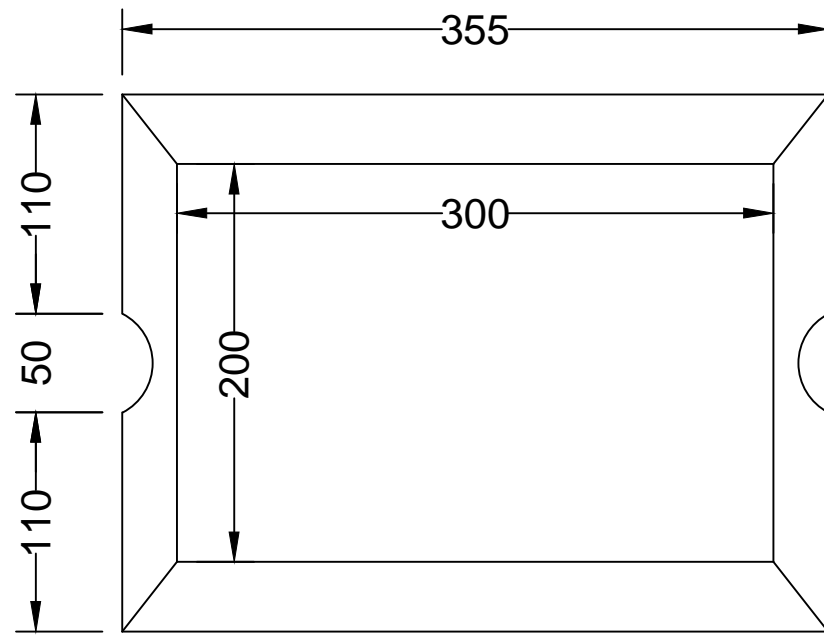

Plan

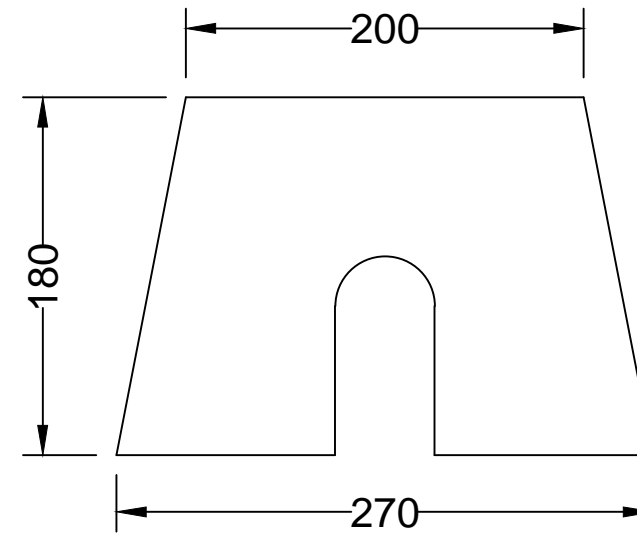

Front View

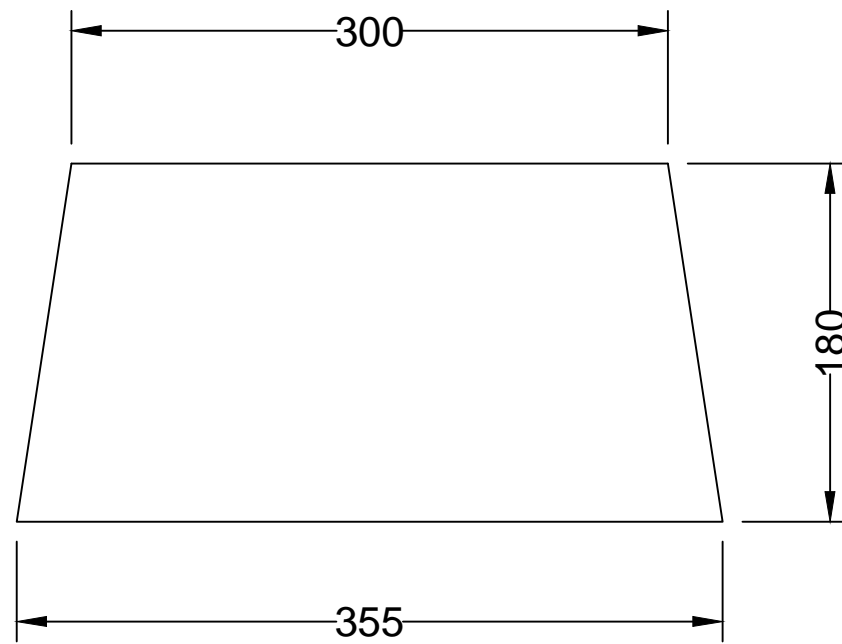

Side View

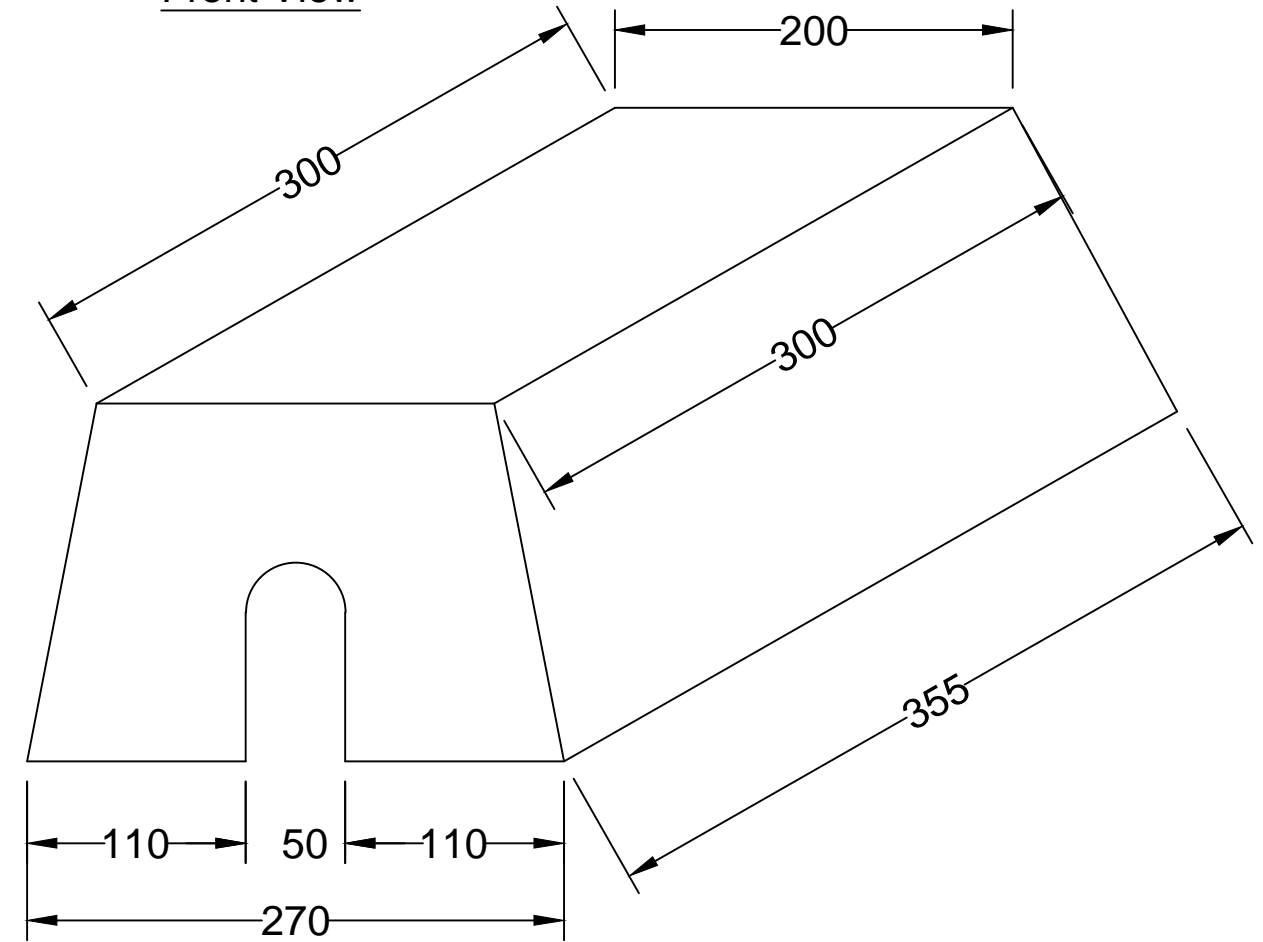

Isometric View

Consultants:
PROJECT MANAGEMENT CONSULTANT (PMC)
 NJS Consultants Co., Limited
 Saikia Commercial Complex,
 3rd Floor,
 Christian Basti,
 G.S.Road
 Guwahati - 781005





Project:
**PROJECT MANAGEMENT CONSULTANTS (ICDC)
 HSC FOR SOUTH WEST GUWAHATI & SOUTH CENTRAL
 GUWAHATI AREA**
 Client:
PROJECT DIRECTOR, PIU
 Saikia Commercial Complex, 2nd Floor, Christian Basti,
 GS Road, Guwahati – 781005, Assam, India.

REV NO.	DATE	REMARKS
3		
2		
1		
0	04.09.2018	For Tendering Purpose

Approved by:	R.Radhakrishnan
Checked by:	BMS Murthy
Drawn by:	H.K. Saikia
Design by:	K.Sathish Kumar
Scale:	Rev:
NTS	

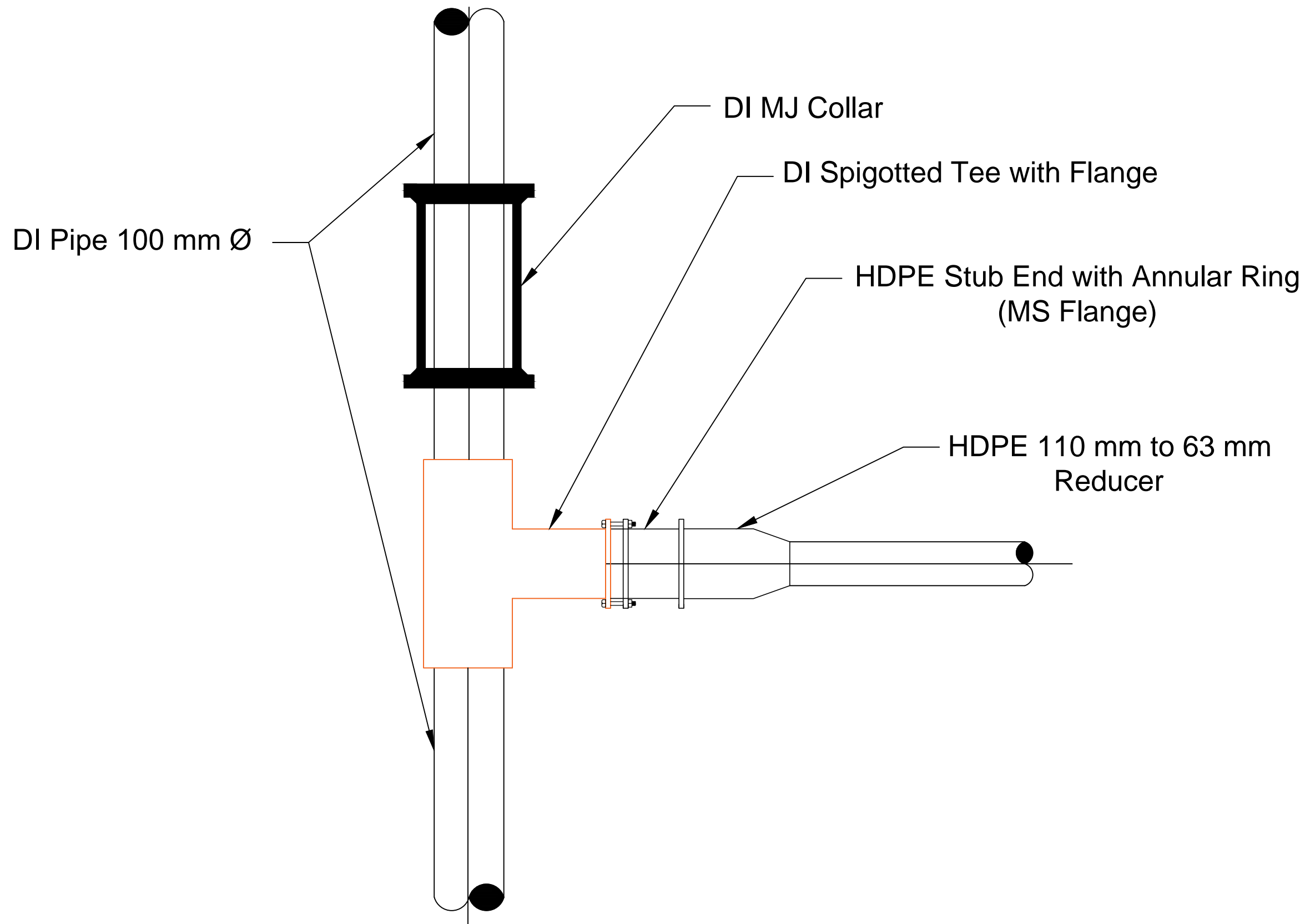
Title: TYPICAL DRAWING FOR WATER METER BOX	
Drawing No. GWSP/HSC/07	Sheet No. 1 of 1



Consultants: PROJECT MANAGEMENT CONSULTANT (PMC) NJS Consultants Co., Limited Saikia Commercial Complex, 3rd Floor, Christian Basti, G.S.Road Guwahati - 781005		Project: PROJECT MANAGEMENT CONSULTANTS (ICDC) HSC FOR SOUTH WEST GUWAHATI & SOUTH CENTRAL GUWAHATI AREA	3			Approved by: R.Radhakrishnan	Title: SKETCH DRAWING HDPE Header Pipe	
		Client: PROJECT DIRECTOR, PIU Saikia Commercial Complex, 2nd Floor, Christian Basti, GS Road, Guwahati – 781005, Assam, India.	2			Checked by: BMS Murthy		
			1			Drawn by: H.K. Saikia		
			0	04.09.2018	For Tendering Purpose	Design by: K.Sathish Kumar		
			REV NO.	DATE	REMARKS	Scale: NTS Rev:		
							Drawing No. GWSP/HSC/08	Sheet No: 1 of 1

Section VII: Contract Forms

LETTER OF ACCEPTANCE CUM NOTICE TO PROCEED WITH THE WORK

Dated: _____

To: _____ [Name and address of the Contractor]

Dear Sir,

This is to notify you that your Bid dated _____ for execution of the Contract Package No. C#12A- Rate contract for providing Drinking Water House Service Connections in lots of 1,000 each, for total of approximately 5,000 households in South-west & south-central Guwahati area, providing all the required goods & materials, install the Employer supplied Water meters, install the pipes & accessories, excavation and road restoration works all complete, for the contract price of Rupees _____ [amount in words and figures], is hereby accepted by us.

You are hereby requested to furnish performance security for an amount of Rs. _____ (equivalent to 10% of the contract price) within 7 days of the receipt of the letter. The Performance Security in the form of Bank guarantee or a Bank draft in favour of "The Project Director, JICA Assisted Guwahati Water Supply Project, Guwahati" (Employer) shall be valid till the expiry of the period of contract and till taking over. Failure to furnish the Performance Security will entail cancellation of the award of contract.

You are also requested to sign the agreement form and proceed with the work not later than _____ under the instructions of the Employer, Project Director, JICA Assisted Guwahati Water Supply Project, Guwahati and ensure its completion within the contract period.

With the issuance of this acceptance letter and your furnishing the required Performance Security, the contract, for the above said work, stands concluded.

Authorized Signature
Name and title of Signatory of Employer

ARTICLES OF CONTRACT AGREEMENT

1. This deed of agreement is made in the form of agreement on _____ day _____ month _____ 20 __, between the Project Director, JICA Assisted Guwahati Water Supply Project, Guwahati (Employer) or his authorized representative (hereinafter referred to as the first party) and _____ (Name of the Contractor), resident of _____ (hereinafter referred to as the second party), to execute the work of: “Rate contract for providing Drinking Water House Service Connections in lots of 1,000 each, for total of approximately 5,000 households in South-west & south-central Guwahati area, providing all the required goods & materials, install the Employer supplied Water meters, install the pipes & accessories, excavation and road restoration works all complete under Contract Package C#12A.” (hereinafter referred to as works) on the following terms and conditions.

2. Contract Price

The total Contract Price for the works (hereinafter referred to as the “total price”) is Rs. _____ as reflected in the annexed Bill of Quantities.

3.1 Payments under its contract:

Payments to the second party for the work will be released by the first party in the following manner:-

On signing of agreement and Mobilization : 10% of total cost, as interest free mobilization advance against receipt of an unconditional Bank Guarantee from the Contractor for an equivalent amount valid up to the Intended Completion Date, in the format attached.

Minimum Amount of Interim Payment Certificates : 10% of the Contract Value

Final payment Certificate : Upon completion & commissioning and handing over.

3.2 Payments at each stage will be made by the first party:

- (a) on the second party submitting an invoice for an equivalent amount;
- (b) on certification of the invoice (except for the first installment) by the Engineer nominated by the first party with respect to quality/quantity of works executed; and
- (c) Payments shall be adjusted for deductions for advance payments, recoveries if any in terms of the contract, and taxes at source, as applicable under the law.
- (d) The advance (if availed by the contractor) shall be repaid with percentage deductions from the interim payments, commencing with the next Interim Payment at the rate of 20 percent of the amounts of all Interim Payment Certificates until the advance has been repaid, provided that the advance shall be completely repaid prior to the expiry of the Intended Completion Date. The Bank Guarantee shall remain effective until the advance payment has been fully repaid.

4. Notice by the Contractor to Engineer

The second party, on the works reaching full completion including trial run & commissioning, issue a notice to the first party or the Engineer nominated by the first party (who is responsible for supervising the contractor, administering the contract, certifying the payments due to the contractor, issuing and valuing variations to the

contract, awarding extensions of time etc.), to visit the site for certification of completion. Within 15 days of the receipt of such notice, the first party or the Engineer nominated by it, will ensure issue of completion certificate after due verification.

Upon issuing the completion certificate, the first party will take over the works.

5. Completion time

The works should be completed in 5 months from the date of this Agreement. In exceptional circumstances, the time period stated in this clause may be extended in writing by mutual consent of both the parties.

6. If any of the compensation events mentioned below would prevent the work being completed by the intended completion date, the first party will decide on the intended completion date being extended by a suitable period:

- a) The first party does not give access to the site or a part thereof by the agreed period.
- b) The first party orders a delay or does not issue completed drawings, specifications or instructions for execution of the work on time.
- c) Ground conditions are substantially more adverse than could reasonably have been assumed before issue of letter of acceptance and from information provided to second party or from visual inspection of the site.
- d) Payments due to the second party are delayed without reason.
- e) Certification for stage completion of the work is delayed unreasonably.

7. Any willful delay on the part of the second party in completing the construction [3 Months] within the stipulated period will render him liable to pay liquidated damages @ 0.10% of the contract value per day which will be deducted from payments due to him. The first party may cancel the contract and take recourse to such other action as deemed appropriate once the total amount of liquidated damages exceeds 3 % of the contract amount.

8. Duties and responsibilities of the first party

8.1 The first party shall be responsible for providing regular and frequent supervision and guidance to the second party for carrying out the works as per specifications. This will include written guidelines and regular site visit of the authorized personnel of the first party, for checking quality of material and construction to ensure that it is as per the norms.

8.2 The first party shall supply one set of drawings, specifications and guidelines to the second party for the proposed works.

8.3 Possession of the site will be handed over to the second party within 7 days of signing of the agreement.

8.4 The Engineer or such other person as may be authorized by the first party shall hold meeting once in a week, where the second party or his representative at site will submit the latest information including progress report and difficulties if any, in the execution of the work. The whole team may jointly inspect the site on a particular day to take stock of activities.

8.5 The Engineer shall record his observations/instructions at the time of his site visit in a site register maintained by the second party. The second party will carry out the instructions and promptly rectify any deviations pointed out by the engineer. If the deviations are not rectified, within the time specified in the Engineer's notice, the first party as well as the

engineer nominated by it, may instruct stoppage or suspension of the construction. It shall thereupon be open to the first party or the Engineer to have the deviations rectified at the cost of the second party.

- 8.6. The first party will provide water at the entry point to the DMA during the trial run and commissioning period.
- 8.7. During the testing & trial run of the Distribution network, while the contractor will be responsible for rectifying any defects in the works done by him; and for the rectification if any required in the lines laid earlier by the previous contractor, the required material, labour and equipment will be provided from the Day works or Provisional Sums in the Contract. .

9. Duties and responsibilities of the second party:

9.1 The second party shall:

- a) take up the works and arrange for its completion within the time period stipulated in Clause 5;
- b) employ suitable skilled persons to carry out the works;
- c) regularly supervise and monitor the progress of work;
- d) abide by the technical suggestions/ direction of supervisory personnel including Engineers etc.;
- e) be responsible for bringing any discrepancy to the notice of the representative of the first party and seek necessary clarification;
- f) ensure that the work is carried out in accordance with specifications, drawings and within the total of the contract amount without any cost escalation;
- g) keep the first party informed about the progress of work;
- h) be responsible for all security and watch and ward arrangements at site till handing over of the building to the first party; and
- i) be responsible for the safety of the men working at site. All safe practices shall be strictly adhered to by the workmen of the contractor like wearing helmets, safety belts when working at heights, gloves when handling sharp objects and reinforcement, eye shields, safety shoes, etc. He shall provide first aid boxes at site. In spite of following safe methods, in case of any unfortunate accident, the contractor shall indemnify the employer against any expenses or claims towards treatment or compensation.
- j) maintain necessary insurance against loss of materials/cash, etc. or workman disability compensation claims of the personnel deployed on the works as well as third party claims.
- k) Pay all duties, taxes and other levies payable by construction agencies as per law under the contract (First party will effect deduction (TDS) from running bills in respect of such taxes as may be imposed under the law). Also deduct 5% as Retention money from the interim payments, which will be released on completion and commissioning of the works.
- l) shall not directly or indirectly sublet the work to other party without written permission from the Employer.
- m) shall carry out the entire work having full regard for the safety of the men working at site. All safe practices shall be strictly adhered to by the workmen of the contractor

like wearing helmets, safety belts when working at heights, gloves when handling sharp objects and reinforcement, eye shields, safety shoes, etc. He shall provide first aid boxes at site. In spite of following safe methods, in case of any unfortunate accident, the contractor shall indemnify the employer against any expenses or claims towards treatment or compensation.

- n) shall be responsible for all injury to persons / animals, any damage to building, building structure, roads, streets and footpaths etc., by his act / during the execution of work and the same shall be rectified at his own cost.
- o) shall maintain all the inventory supplied by him including the equipment if any supplied by the Employer.
- p) After execution of the works in all respect, the Contractor shall do testing, trial run of the entire Distribution system network in the DMA for a period of 90 days. If required by the Employer, the period may be extended at the rates quoted in the contract, as a variation.
- q) During the testing & trial run, the contractor will be responsible for rectifying any defects in the works done by him; and for the rectification if any required in the lines laid earlier by the previous contractor, the required material, labour and equipment will be provided from the Day works or Provisional Sums in the Contract. .

10. Variations / Extra Items

The works shall be carried out by the second party in accordance with the approved drawings and specifications. However, if, on account of site conditions or any other factors, variations are considered necessary, the following procedure shall be followed:-

- a) The second party shall provide the Engineer with a quotation for carrying out the Variation when requested to do so by the Engineer. The Engineer shall assess the quotation, which shall be given within seven days of the request before the Variation is ordered.
- b) If the quotation given by the second party is unreasonable, the Engineer may order the Variation and recommend a change to the Contract Price, which shall be based on Engineer's own forecast of the effects of the Variation on the Contractor's costs.
- c) The second party shall not be entitled to additional payment for costs which could have been avoided by giving early warning.

11. Securities

The Performance Security (Bank Guarantee from a Nationalized or Scheduled Bank in India in the format attached) shall be provided to the Employer no later than the date specified in the Letter of Acceptance and shall be issued in an amount and form and by a Bank or surety acceptable to the Employer. The Performance Security shall be valid until a date 28 days after the end of the Defects Liability Period.

This security shall be retained by the Employer and when the certificate of the virtual completion is issued to the contractor, the Performance security will be reduced to 50%. The balance 50% of the Security will be returned to the contractor after the expiry of defect liability period, subject to deductions for any appropriations thereof required to be made by the Employer as per conditions of the contract. The contractor should note that no interest will be allowed on the security deposit.

12. Termination

12.1 The Employer may terminate the Contract if the other party causes a fundamental breach of the Contract.

12.2 Fundamental breaches of Contract include, but shall not be limited to the following:

- (a) the contractor stops work for 7 days and the stoppage has not been authorized by the Engineer;
- (b) the Contractor has become bankrupt or goes into liquidation other than for a reconstruction or amalgamation;
- (c) the Engineer gives Notice that failure to correct a particular Defect is a fundamental breach of Contract and the Contractor fails to correct it within a reasonable period of time determined by the Engineer;
- (d) the Contractor does not maintain a security which is required;
- (e) the Contractor has delayed the completion of the Works by the number of days for which the maximum amount of liquidated damages can be paid, as defined in the Clause 7 of this agreement

12.3 Notwithstanding the above, the Employer may terminate the Contract for convenience.

12.4 If the Contract is terminated, the Contractor shall stop work immediately, make the Site safe and secure, and leave the Site as soon as reasonably possible.

13. Payment upon Termination

13.1 If the Contract is terminated because of a fundamental breach of Contract by the Contractor, the Engineer shall issue a certificate for the value of the work done less advance payments received up to the date of the issue of the certificate, less other recoveries due in terms of the contract, less taxes due to be deducted at source as per applicable law.

13.2 If the Contract is terminated at the Employer's convenience, the Engineer shall issue a certificate for the value of the work done, the reasonable cost of removal of Equipment, repatriation of the Contractor's personnel employed solely on the Works, and the Contractor's costs of protecting and securing the Works and less advance payments received up to the date of the certificate, less other recoveries due in terms of the contract and less taxes due to be deducted at source as per applicable law.

14. Dispute settlement

If over the works, any dispute arises between the two parties, relating to any aspects of this Agreement, the parties shall first attempt to settle the dispute through mutual and amicable consultation.

In the event of agreement not being reached, the matter will be referred for arbitration by a Sole Arbitrator not below the level of retired Superintending Engineer, Assam PHED/AUWSSB to be appointed by the first party. The Arbitration will be conducted in accordance with the Arbitration and Conciliation Act, 1996. The decision of the Arbitrator shall be final and binding on both the parties. The Arbitrator shall give his award/decision within 60 days of start of proceedings.

The Priced Bill of Quantities (Annexure 1), Format of Certificate (Annexure 2) and Specification and Drawings (Annexure 3) are attached.

Signed and delivered by Mr. _____ for and on behalf of the Contractor

In the presence of the Witness:

i)

ii)

SIGNATURE

Signed and delivered by Mr. _____ Project Director, JICA Assisted Guwahati Water Supply Project, Guwahati.

In the presence of the Witness:

i)

ii)

SIGNATURE

PERFORMANCE BANK GUARANTEE
(To be given from a nationalized or scheduled bank in India)

To
 Project Director,
 Project Implementation Unit,
 JICA Assisted Guwahati Water Supply Project,
 II Floor, Saikia Commercial Complex
 Christian Basti, G.S Road, Guwahati – 781 005

WHEREAS _____ [*name and address of Contractor*] (hereinafter called "the Contractor") has undertaken, in pursuance of Contract No. _____ dated _____ to execute "Rate contract for providing Drinking Water House Service Connections in lots of 1,000 each, for total of approximately 5,000 households in South-west & south-central Guwahati area, providing all the required goods & materials, install the Employer supplied Water meters, install the pipes & accessories, excavation and road restoration works all complete under Contract Package C#12A", (hereinafter called "the Contract");

AND WHEREAS it has been stipulated by you in the said Contract that the Contractor shall furnish you with a Bank Guarantee by a recognized bank for the sum specified therein as security for compliance with his obligations in accordance with the Contract;

AND WHEREAS we have agreed to give the Contractor such a Bank Guarantee;

NOW THEREFORE we hereby affirm that we are the Guarantor and responsible to you, on behalf of the Contractor, up to a total of _____ [*amount of guarantee*]¹ _____ [*in words*], such sum being payable in the types and proportions of currencies in which the Contract Price is payable, and we undertake to pay you, upon your first written demand and without cavil or argument, any sum or sums within the limits of _____ [*amount of guarantee*]¹ as aforesaid without your needing to prove or to show grounds or reasons for your demand for the sum specified therein.

We hereby waive the necessity of your demanding the said debt from the Contractor before presenting us with the demand.

We further agree that no change or addition to or other modification of the terms of the Contract or of the Works to be performed there under or of any of the Contract documents which may be made between you and the Contractor shall in any way release us from any liability under this guarantee, and we hereby waive notice of any such change, addition or modification.

This guarantee shall be valid until 28 days from the date of expiry of the Defects Liability Period.

Signature and seal of the guarantor _____
 Name of Bank _____
 Address _____
 Date _____

BANK GUARANTEE FOR ADVANCE PAYMENT

To
 Project Director,
 Project Implementation Unit,
 JICA Assisted Guwahati Water Supply Project,
 II Floor, Saikia Commercial Complex
 Christian Basti, G.S Road, Guwahati – 781 005

Name of Contract: Contract Package No. C#5B-5R7: Procurement of Works (Item rate) for Supply, Installation & Commissioning of Employer furnished D.I Pipes for the balance works under the Distribution Network in the DMA No. 5R7 of Ramsahill of South- Central Zone

Gentlemen:

In accordance with the provisions of the Conditions of Contract, sub-clause 3.1 of the above-mentioned Contract, _____ [name and address of Contractor] (hereinafter called "the Contractor") shall deposit with _____ [name of Employer] a bank guarantee to guarantee his proper and faithful performance under the said Clause of the Contract in an amount of _____ [amount of guarantee]¹ _____ [in words].

We, the _____ [bank or financial institution], as instructed by the Contractor, agree unconditionally and irrevocably to guarantee as primary obligator and not as Surety merely, the payment to Project Director, JICA Assisted Guwahati Water Supply Project, Guwahati – 781 005 [Employer] on his first demand without whatsoever right of objection on our part and without his first claim to the Contractor, in the amount not exceeding _____ [amount of guarantee]¹ _____ [in words].

We further agree that no change or addition to or other modification of the terms of the Contract or of Works to be performed thereunder or of any of the Contract documents which may be made between Project Director, JICA Assisted Guwahati Water Supply Project, Guwahati – 781 005 [Employer] and the Contractor, shall in any way release us from any liability under this guarantee, and we hereby waive notice of any such change, addition or modification.

This guarantee shall remain valid and in full effect from the date of the advance payment under the Contract until _____ [name of Employer] receives full repayment of the same amount from the Contractor.

Yours truly,

Signature and seal: _____
 Name of Bank/Financial Institution: _____
 Address: _____
 Date: _____

¹ An amount shall be inserted by the bank or financial institution representing the amount of the Advance Payment, and denominated in Indian Rupees.

CONTRACT DATA

1. **Compliance to local laws:** The contractor shall conform to the provisions of any Act of the Legislature relating to the work and to the Regulation of Bye Laws of any prevalent authority. He shall also obtain all necessary permission / approval / NOC from the competent authorities for completion of the said work, if required under the existing rules.
2. **Site cleaning:** All the rates quoted are inclusive of removal of rubbish / debris collected during the progress of work, rejected material and clearance of site before and after the work is completed. The contractor shall arrange to remove the same immediately. If the contractor fails to do so, Employer shall remove the same and the expenses thus incurred shall be recovered from the contractor and no claim of any sort will be entertained.
3. **Contractor's responsibility:** The work from time to time be examined by Employer's Engineer, but such examination shall not in any way exonerate the contractor from the obligation to remedy any defects which may be observed at any stage of the work or after the same is completed.
4. **Dismissal from work:** The contractor shall upon the written request of the Employer's Engineer immediately dismiss from the work any person employed by him thereon, who may in the opinion of the authority be incompetent or misconducts himself and such person shall not be again employed on the work, without the permission of the Employer .
5. **Order of work:** Employer reserves the right to fix the order in which the various items of work involved are to be executed. However, the contractor shall be responsible for the completion of the entire job within the item limit specified, failing which liquidated damages shall be payable by the Contractor.
6. **Distribution of work:** The Employer reserve the right to distribute the work for which Tender have been called, among more than one parties, if found necessary. No claim in this respect shall be considered and the contractor shall agree to cooperate with other agencies appointed by the Employer.
7. **Third party damage:** The contractor shall be responsible for all injury to persons / animals, any damage to building, building structure, roads, streets and footpaths etc., by his act / during the execution of work and the same shall be rectified at his own cost.
8. **Insurance cover:** All the workers of the contractor as well as his sub-contractors must be properly covered by an Insurance Policy under Workman's Compensation Act and Fatal Accidents Act. The contractor at his own expenses shall arrange to effect and maintain, until the virtual completion of the contract, insurance policy in the joint name of the Employer and the contractor against this risk, which is to be retained by the Employer until the actual completion of the work, and indemnify the Employer from all the liabilities arising out of such events. In case of delay, contractor shall arrange to extend insurance policy till work is completed.

Insurance Cover for Material/ workmanship: Insurance for the theft of Materials, damage during fixing for the materials and pipes shall be taken by the Contractor at his cost and kept alive till the completion of the Contract
9. **Inventory Management:** The Contractor shall maintain all the inventory supplied by him including the equipment if any supplied by the Employer.
10. **Certificate of virtual completion:** As soon as the work is completed, the contractor shall inform in writing such completion to the Employer's Engineer who will inspect the work and if satisfied will issue the certificate that the work has been virtually completed and the defects liability period shall commence from the date of such certificate.
11. **Defect liability period:** The defects or other faults which may appear during the defect liability period which is 12 months after the virtual completion of the work [lot], arising in the opinion of the

Employer due to bad workmanship not in accordance with the contract, contractor shall make good the works at his own cost within a reasonable time. In case of default, Employer may employ and pay other agencies to amend and make good such defects and all expenses / damages / losses shall be recoverable by Employer or may be deducted from any money due to the contractor.

12. **Arrangement of work:** The contractor shall organize the work in such a way that the nearby public areas are not subjected to any hardships and the working of the habitat is not affected. The contractor shall take adequate care during the progress of work to protect the consumer property. In case of any damage, the same shall be made good by the contractor and no claim in this regard shall be entertained. If Contractor agrees to work after office hours/during night, for this no extra cost shall be considered.
13. **Stacking of material:** The contractor is not to stack any of his material recklessly so as to endanger the safety of the surrounding and cause any nuisance to the occupants and the public.
14. **Extra charges:** It is clearly implied that all the conditions of contract are intended to be strictly enforced and that no extra charges in respect of extra work will be allowed unless they are clearly outside the spirit and meaning of the condition and unless such work shall have been ordered in writing.
15. **Protection of material and work:** The contractor shall be responsible for storing and watching his own material and protecting the work at his own cost. Any damage caused during such act will have to be made good by the contractor at his own expenditure.
16. **Water supply:** The contractor shall make his own arrangement for water required for the work. In case the water is available and supplied by the Employer, the charges for the same shall be recovered. In case water supplied by the Employer, the contractor shall make his own arrangement for the storage.
17. **Workmanship:** The work involved calls for a high standard of workmanship combined with speed. All the properties are to be thoroughly cleaned after work is completed. Any damage to the property or any other part of the building, etc. shall be made good at the cost of the contractor to the entire satisfaction of the Employer.
18. **Interpretation of documents / drawing:** Except where otherwise provided in the contract all questions and disputes relating to the meaning of the specifications, design drawings and instructions herein before mentioned and as to the quality of workmanship or materials used for the work or as to any other question, claim, right, matter or thing whatsoever, in any way arising out of or relating to the contract, designs, drawings specifications, estimates, instructions, orders or these conditions or otherwise concerning the works, or the execution or failure to execute the same whether arising during the progress of the work or after the completion or abandonment thereof shall be referred to the competent authority of the Employer whose decision shall be final and binding on the contractor.
19. **Use of scaffolding:** The contractor shall use the shoring / shuttering materials, wherever required, for which no extra payment will be made.
20. **Provisional Item:** If ordered by the Employer, contractor shall be required to carry out provisional items at the same conditions and rates as applicable for this contract.
21. **Measurements of all concealed items:** Measurements of all concealed items of work and extra item if any, shall be got recorded by the Employer's Representative Engineer before it is concealed or covered.
22. **Complying I.S. specification:** Unless otherwise mentioned in the contract, the latest Indian Standard Code for material specifications, method of work, and mode of measurements shall be followed. The payment shall be made on the basis of actual measurement of work done to be submitted along with bill.

- 23.**Rate to include:** The rates quoted by the contractor shall cover for work at any height on/below the ground for all finished items under this contract. The rate quoted shall be inclusive of all labour, loading, profit, taxes & duties including GST, testing and commissioning of the Service Connections and related works. If there is any change in the tax structure / duties as per the Govt. order, after award of contract, the rates quoted will be adjusted accordingly.
- 24.**Price Fluctuation:** The rates quoted by the contractor shall be firm throughout the currency of contract (including extension of time if any granted) and will not be subject to any fluctuation due to variation in the cost of labour/Materials.
- 25.**Rates of non-tendered items:** The successful tenderer is bound to carry out any item of work necessary for the completion of the job with no additional cost, even though such items are not included in Bill of quantities.
- 26.**Abandonment of work:** If in any case the work is required to be abandoned, the contractor shall not be entitled for any claims on that account and he will be paid as per the actual work done till that period.
27. When the work has been virtually completed and Employer's Representative Engineer has certified in writing that the work has been completed on the basis of detailed measurements and has made a final scrutiny and that there is no dispute on items, rates, and quantities, the contractor shall be entitled to the payment of the final bill in accordance with the final certificate which will be honored within the period specified in the Contract as period of honoring final certificate.
- 28.The contractor shall be paid by the Employer within the period named in Contract, after Interim Payment certificate has been delivered to the employer by the Employer's Representative Engineer. Employer's Representative Engineer has power to withhold any certificate in the work or any part thereof are not carried out to his satisfaction or the contractor fails to show the desired progress or fails to follow the instructions given or in case of breach of this contract.
- 29.**Records & measurements:** Measurements shall be taken jointly by Employer's Representative Engineer and contractor and shall without extra charges provide assistance with appliance/ Equipment; labour and other things necessary for the work and measurements will be signed and dated by both the parties on completion of measurements. Only on completion of works relating to providing the service connection and installation of water meter, it will measured for payment.
- 30.If there is delay in commencement of work for any reason, the employer shall not be liable for payment of any compensation.
- 31.**First Aid:** The contractor shall be responsible for all first aid and he shall keep the site fully equipped to meet such emergency.
- 32.**Supervision:** The contractor is required to have on site during all working hours a competent supervisor (acceptable to Employer) who will be responsible for the conduct of workers and who has authority to receive and act on such instructions issued by the Representative Engineer of Employer.
33. All work shall be carried out in a workman-like manner to the entire satisfaction of Employer Representative Engineer.
- 34.Contractors shall follow all rules / regulations in force and should possess the license for employing labour and also follow all safety measures, labour bye-laws and shall be responsible for any lapse.
- 35.**Safety:** The contractor shall carry out the entire work having full regard for the safety of the men working at site. All safe practices shall be strictly adhered to by the workmen of the contractor like wearing helmets, safety belts when working at heights, gloves when handling sharp objects and reinforcement, eye shields, safety shoes, etc. He shall provide first aid boxes at site. In spite of following safe methods, in case of any unfortunate accident, the contractor shall indemnify the employer against any expenses or claims towards treatment or compensation.

36. **Daily Diary Register:** A daily diary register will be kept in the Engineer's Office or the site office. The contractor or his representative will furnish every day at 9.00 am details of work for the day proceeding and the diary will be written up every day and jointly signed by the Engineer and the Contractor or their representatives in token of its correctness.
37. **Nuisance:** The contractor shall not any time do cause or permit anyone to do or cause any nuisance on the site or do anything which shall cause unnecessary disturbance of inconvenience to the Employer or to the owners, tenants or occupiers of other properties near the site and to the public generally.

Trained Plumber Details

Sl.No.	Name of the Applicant	Registration Number	Mobile Number
1	Harendra Kumar Sarma	U16000134105	8486683416
2	Bilap Sarma	U16000134102	9085896302
3	Parag Sarma	U16000134107	9954607371
4	Biju Talukdar	U16000134108	9508030477
5	Jintu ali	U16000134111	9577163811
6	Abbul Latif	U16000134109	9085616229
7	Mukul Kumar Barman	U16000134103	8486316771
8	Parag Jyoti kalita	U16000134114	9854549408
9	Shiv Sankar Das	U16000134104	8753870842
10	Bhaskar kalita	U16000134112	8876610848
11	Maneswar Kalita	U16000134106	9085562560
12	Dhanjit Kalita	U16000134098	8473838994
13	Jyotirmoy Patowary	U16000134120	8399053948
14	Nadan Rabha	U16000134100	9577630526
15	Hemen Saikia	U16000134124	8751888058
16	Manoj Barman	U16000134123	9706076194

17	Shuchand Ali	U1600013421	9864472061
18	Dhanjit Bharali	U16000134117	8723929439
19	Akan Barman	U16000134113	9132537851
20	Apurba Rabha	U16000134097	9613846249
21	Nayan Jyoti Das	U16000134116	8876492734
22	Udit Narayan Roy	U16000134115	8876827783
23	Dhruba Jyoti Nath	U16000134119	7035397941
24	Bitu Kalita	U16000134118	7086414737
25	Nayan Muni Baishya	U16000134101	8254025513
26	Diganta Kalita	U16000134099	8473838994-
27	Bijoy Krishna Sarmah	U16000134122	9957616107
28	Mohibul Islam	U16000134110	8472075925
29	Bharat Deori	U16000134450	9613162725
30	Ritupon Bora	U16000134438	9706873649
31	Rakesh Gogoi	U16000134456	9957321570
32	Santanu Bhuyan	U16000134440	98647044659
33	Gourab Borgohain	U16000134432	9954548225
34	Mrigendra Phukan	U16000134416	9577282465

35	Pranab Jyoti Hazarika	U16000134005	8721036798
36	Chandan Borah	U16000134424	8749991208
37	Partha Jit Borah	U16000134410	9613003701
38	Anshuman Dutta	U16000134420	9706567280
39	Dipak Mahtu	U16000134444	8474885301
40	Biraj Gogoi	U16000134428	9859157499
41	Goutam Bora	U16000134436	8723807594
42	Santonu Khanikar	U16000134407	8486324190
43	Rishi Das	U1600134434	9706055041
44	Tridip Saikia	U16000134454	9085008647/9085339303
45	Manab Pegu	U16000134451	8752827046
46	Mridul Gogoi	U16000134448	9678168960
47	Nayan Jyoti Borah	U16000134408	9954447841
48	Anupam Das	U16000134442	9954600953
49	Aditya Dutta	U16000134412	8876802299
50	Pritom Gohain	U16000134402	9854588259
51	Dhani Ram Yein	U16000134446	7896980108
52	Raktim Saikia	U16000134418	9854042335

53	Amlan Jyoti Sarmah	U16000134414	7399549773
54	Ankur Bora	U16000134453	9954609785
55	Hari Prasad Das	U16000134452	9707539967
56	Pranjal Sharma	U16000134411	9954640351
57	Biman Das	U16000134455	9959458176
58	Biju Paul	U16000134400	8011593213
59	Chidananda Das	U16000134424	9577506943
60	Sidartha Saikia	U16000134398	9706978290
61	Sandipan Saikia	U16000134429	78963-91338
62	Bikram Biplab Chutia	U16000134426	96782-81170
63	Pradip Malakar	U16000134447	83998-42954
64	Dipankar Borah	U16000134396	9706753704
65	Sanjib Tamuli	U17000026820	84020-43384
66	Padma Narayan Das	U17000026811	7577901554
67	Jayanta Borah	U17000026826	84728-04244
68	Parash Moni Hazarika	U17000026831	94011-13304
69	Utpal Padun	U17000026808	87209-49197
70	Bhaskar Gogoi	U17000026825	87219-98591

71	Jayanta Chetia	U17000026828	98543-09925
72	Ashis Borthakur	U17000026832	97061-03088
73	Manash Protim Borah	U17000026824	70863-55216
74	Simankar Bora	U17000026837	7637980854
75	Debojit Das	U17000026816	87240-38188
76	Diganta Neog	U17000026833	8876508941
77	Dupan Pachani	U17000026810	87209-81099
78	Khargo Jyoti Gogoi	U17000026836	84864-90342
79	Manash Jyoti Dutta	U17000026815	97062-23484
80	Biswadeep Baruah	U17000026809	97063-77764
81	Protim Borah	U17000026814	73996-45625
82	Bidyut Bora	U17000026817	88120-00678
83	Mridul Borah	U17000026835	84730-80499
84	Partha Gogoi	U17000026818	96786-73392
85	Amir Uddin Ahmed	U17000026807	88760-57526
86	Dipankar Phukon	U17000026827	9864021908
87	Sunumunu Saikia	U17000026822	96132-28384
88	Dhurbajit Sonuwal	U17000026830	83999-35645

89	Abhijit Dutta	U17000026821	87530-29138
90	Rahul Chetia	U17000026812	9706502365
91	Atifur Rahman	U17000026806	84719-98024
92	Johnmajoy Basumatary	U17000026823	9613605787
93	Dhorani Pachani	U17000026834	7035817857
94	Ritupon Kachari	U17000026819	8486664104
95	Rubul Das	U17000026813	NA
96	Arabinda Sarmah	U17000026829	NA
97	Jentu Borah	U17000030073	7896533635
98	Sagar Dutta	U17000030083	9859574394
99	Basanta Das	U17000030062	7896463451
100	Pranjal Saikia	U17000030082	9854215927
101	Dhurba Jyoti Saikia	U17000030066	88763-45433
102	Swapnanil Bora	U17000030084	96132-60679
103	Dadu Kalita	U17000030068	9957112655
104	Rustom Saikia	U17000030081	81338-10814
105	Manash Das	U17000030079	8486949063
106	Kishor Kr.Deka	U17000030075	9613358222

107	Anupom Buragohain	U17000030059	7577099847
108	Bedanta Boruah	U17000030063	84866-89112
109	Deepak Telenga	U17000030067	9854846831
110	Chinmoy Hazarika	U170000300685	8876945022
111	Diganata Boruah	U17000030070	8761871917
112	Mukut Das	U17000030076	9706565736
113	Mahi Ram Nath	U17000030077	9854377305
114	Hangshadhar Sarma	U17000030072	9864036335
115	Bitupan Borah	U17000030064	9613915699
116	Ratul Talukdar	U17000030080	9085013821
117	Dipankar Barman	U17000030069	9854258782
118	Abijit Kr Haloi	U17000030060	9085331838
119	Amarjyoti Deka	U17000030061	8876987700
120	Debananda Das	U17000030071	8876852232
121	Manab Jyoti Chetia	U17000030078	73992-33201
122	Jatin Pradhan	U17000030074	8403887083
123	Hirak Jyoti Mahanta	U16000196011	95085-94244
124	Ramen Das	U16000196010	88128-98633

125	Kaushik Nath	U16000196004	9859917262
126	MANTU KAKATI	U16000196007	9678729668
127	Hirak Jyoti Deka	U16000195933	7399511775
128	Hirakjyoti Deka	U16000196000	7664967461
129	RINKU MANI RAJBONGSHI	U16000195998	8486988201
130	Khanindra Deka	U16000195990	9678709183
131	Hitesh Das	U16000196009	9127015083
132	Saurav Deka	U16000196006	8486799363
133	Amal Rajbongshi	U16000196005	9085402823
134	APURBA SWARGIARY	U16000196003	8486517264
135	ZAKIR HUSSAIN	U16000196001	8723003662
136	MINUL HOQUE	U16000195999	8876662144
137	DIGANTA DAS	U16000195985	8403806427
138	DIMBESWAR DAS	U16000195994	8486519747
139	DEBARAJ KALITA	U16000195997	9085862595
140	Pranjit Das	U1600019582	73992-94553
141	Kashyap Nath	U16000195995	91274-32797
142	HEMANTA DAS	U1600019583	8486821945

143	Arup Kalita	U16000195987	83990-02186
144	SANU KUMAR	U16000195981	8134075507
145	Dipjyoti Barman	U16000195984	8724844248
146	Utpal Sarma	U16000195986	9954803051
147	Sushanta Bharali	U16000195991	8720927754
148	Manash Jyoti Sarmah	U16000195992	9954136701
149	Pradip Gogoi	U16000195988	73998-74731
150	Nipam Das	U16000195989	9577893285
151	Bipul Das	U1600096008	8486864379
152	KANKAN KALITA	U16000196002	8876174792
153	Diraj das	U16000195996	8486926870
154	Heman Boro	U16000213460	9954226508/ 8399826090
155	Hemanta Deka	U16000213461	9864096318
156	Munindra Pathak	U16000213471	9854140183
157	Jyoti Hazarika	U16000213463	9577672092
158	Rakesh Mudiar	U16000213477	9085819276
159	Gautam Bharali	U16000213457	9957631789 / 8876547319
160	Kishor Tamuli	U16000213468	97079-17755

161	Tikendrajit Das	U16000213482	94765-21145
162	Dipam Baishya	U16000213456	9954931659
163	Naba Kumar Das	U16000213473	98544-03852
164	Tankeswar Deka	U16000213481	99577-59655
165	Ramesh Boro	U16000213478	99542-06867
166	Sanjib Borah	U16000213480	9707827700
167	Chandan Chamuah	U16000213455	88766-93861
168	Hirak Jyoti Talukdar	U16000213458	96782-84634
169	Jayanta Deka	U16000213464	7896942406
170	Munin Goswami	U16000213469	9707175636
171	Pranab Kalita	U16000213475	88768-60924
172	Naba Jyoti Das	U16000213473	8723961638
173	Pankaj Baruah	U16000213474	9706088225
174	Rekibuddin Ahmed	U16000213476	7399783150
175	Jatin Morang	U16000213465	9864531545
176	Afjal Hussain	U16000213453	98648-01234
177	Idul Hussain	U16000213462	9864307777
178	Samar Jyoti Baishya	U16000213479	8876436390

179	Bhupen Kumar	U16000213454	8876381938
180	Kaushik Das	U16000213466	7663847369
181	Himanshu Thakuria	U16000213459	8473092986
182	Mohammad Ali Barbhuiya	U16000213470	98544-31557
183	Kumar Uria	U16000213467	7578088528
184	Wasim Aktak	U17000010301	7664981410
185	Mozahidul Islam	U1700010279	7002462004-9957734593
186	Tahir Uddin Talukdar	U17000010298	9401043079
187	Rabiul Hussain	U17000010283	8822438728
188	Udit Kumar Sarma	U170000103000	8822208735
189	Binod Das	U17000010265	97073-64749
190	Someswar Rabha	U17000010295	8724954251
191	Uddhab Barman	U17000010299	9085612415
192	Tanju Mahanti	U17000010297	9859182206
193	Nayan Nath	U17000010286	9706275534
194	Nirankush Sharma	U17000010283	8486183184
195	Nirmal Biswakarma	U17000010281	8135817007
196	Dip Jyoti Nath	U17000010269	8876644727

197	Giyas uddin Sheikh	U17000010270	9678387655
198	Azim Ali	U17000010264	7399848487
199	Sri Sanjoy Das	U17000010294	7086834614
200	Kamal Das	U17000010276	8472880816
201	Rajib Gayan	U17000010291	9954096526
202	Pranjal Das	U17000010287	8486243661
203	Dhruba Jyoti Sarma	U17000010267	9859891633
204	Abdul Bashate Khan	U17000010263	87219-94751
205	Kaushik Deka	U17000010275	8254825642
206	Manoj Das	U17000010278	84867-18758
207	Ankur Kakati	U17000010262	9859415247
208	Rahma Ali	U17000010292	8486892408
209	Jiten Turi	U17000010272	9706571755
210	Makbull Hussain	U17000010280	9859373683
211	Gokul Borah	U17000010271	7576024580
212	Tapan Talukdar	U17000010296	8472819963
213	Thanu Gogoi	U17000010523	9613915840
214	Prabin Kalita	U17000010288	9707022836

215	Rana Borah	U17000010290	9864794241/ 9864471155
216	Nur Mohd. Ali	U17000010282	9706932681
217	Jayanta Deka	U17000010273	8473948822
218	Nipu Dutta	U17000010285	8472862670/ 8486392005
219	HIMU DAS	U17000010274	9706220460
220	Mushahid Hussain	U170000102777	8472077212
221	Dijoraj Roy	U17000010268	9706658103
222	Nipu Buragohain	U17000010284	8752968977
223	Raju Boro	U17000010289	8486256402
224	Chintumoni Das	U17000010266	9859271965
225	Amarendra Sarma	U17000010261	7399541486
226	Mohibul Hoque	U17000011801	9954774350
227	Kamal Chandra Nath	U17000011798	90859-39523
228	Abhijit Deori	U17000011776	95085-88347
229	Hiren Das	U17000011782	84866-94754
230	Sajidur Rahman Borah	U17000011788	8723841389
231	Jitu Moni Das	U17000011797	9859846827
232	Jewel Ali	U1700001176	84020-01738

233	Rupjyoti Gogoi	U1700001176	9613247237
234	Dildar Khan	U17000011780	9706443728
235	Girish Chandra Haloi	U17000011781	98590-92213
236	Mridul Bora	U17000011802	8876453498
237	Kankan Hazarika	U170000011799	9706198834/ 9577069066
238	Nurjamal Hoque	U17000011805	96781-73154
239	Akijur Hoque	U17000011779	8753900646
240	Mohibul Islam	U17000011800	8486052868
241	Afidul Paramanik	U17000011772	90859-49145
242	Shri Hemanta Kr.Nath	U17000011783	9864758976
243	Mohidul Islam	U17000011803	9678155015
244	Abu Sidique	U17000011775	7663059484
245	Son Mani Deka	U17000011792	7664926678
246	Anizul Sheikh	U17000011777	9085208566
247	Jahirul Islam	U17000011795	7399194043
248	Nitul Das	U17000011806	94014-70085
249	Sankar Kalita	U170000117887	7896137705
250	Sofikur Rahman	U17000011793	88102025729

251	Rakibur Rahman	U17000011785	8486931149
252	Mohan Chamaria	U17000011804	9864051253
253	Shahanur Alom Ahmed	U17000011790	9957435700
254	MD Washim Akram	U17000011807	7664891661
255	Shariful Islam	U17000011789	9957043985
256	Shohidul Mondal	U1700001794	7577001126
257	Ranodhir Chandra Nath	U17000011784	8404017024
258	Abdul Awal Mollah	U17000011778	8471829338
259	Sarimul Haque Laskar	U17000011791	9854550213
260	Abuul Kader	U1700001773	9954683004
261	Abdul Awal Mollah	U17000011778	7664895750

	Total -261 candidates
--	-----------------------